

SAFETY WARNING SIGNS

This sign denotes a safety warning.

The information behind the sign include important safety information.

Please read and understand this information to prevent personal injuries or deaths.

The machine owner or employer is responsible for instructing every operator to operate all equipment correctly and safely in detailed manner. All personnel operating this machine shall sufficiently understand the contents of this manual.

Before operating the machine, all operation personnel must receive the guidance on related functions of excavator.

Before operating this machine in a working site, learn and practice how to use the machine controls correctly in a safe and spacious place.

The improper methods during operations, checking, and maintenance of machine will result in injuries or deaths. Before any operation, checking, or maintenance of machine, please read and understand this manual.

Please always carry this manual with you. It's preferable to preserve this manual on the machine. If this manual is lost or damaged, please immediately order a new manual from a dealer. At the transfer of this machine, please ensure to hand this manual over to the new owner.

SIGNAL WORDS

The safety information on this manual and machine identifications is indicated by words "Danger", "Warning", and "Notice". The meanings of these signal words are as below:



DANGER

"Danger" denotes high dangerous level, for which the negligence will result in death or serious injury.



WARNING

"Warning" denotes medium danger level, for which the negligence will probably result in death or serious injury.



NOTICE

"Notice" denotes low danger level, for which the negligence will result in minor or medium injuries.

Important: The word “Importance” is intended to alert the operation and maintenance personnel of the possible damages of machine and its components.

It's impossible for us to predict all possibly existed dangers. Therefore, the warnings in this manual or on this machine can't cover all possible accidents. Therefore, during the operations of machine, ensure to take cautions and abide by all conventional safety measures to prevent harms to machine, operation personnel, or other personnel.

INTRODUCTION

Foreword

This manual describes the operations, checking, and maintenance of this machine and the safety descriptions to be observed during operations.

- In some details, this manual probably differs from the manual attached on the machine in use.
- Please be noted that the information contained in this manual and the parameters of machine are subject to changes without further notice.

Serial number

Important: Do not disassemble the machine nameplate with serial number. Observe the serial numbers of machine and engine and record them in the blank area below.

Machine No.:

Engine No.:

Front, Rear, Left, and Right

The front, rear, left, and right of the machine indicated in this manual are based on the pedal, facing the bucket.

Front

Designated Operations

This machine is mainly applied for following operations:

- Mining
- Backfill
- Leveling
- Stacking materials
- Loading materials
- Moving pallet cargo

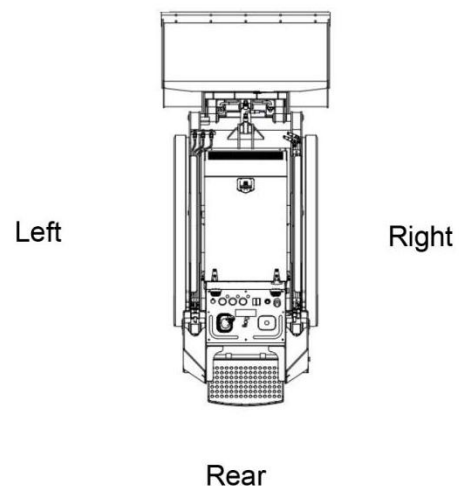

Product Features

- Small size, flexible operation
- Can be equipped with a variety of attachments
- Easy to operate, Efficient and energy-saving

Run-in period

For the first 100 hours of the new machine (as indicated by the timer), please follow the instructions below:

Using the new machine without run-in will deteriorate acceleration performance and probably shorten the life of machine.

- Sufficiently warm up the engine and hydraulic oil.
- Avoid heavy-load and rapid operations. Maintain the load at approximately 80% of maximum load capacity during operations.
- Do not start, accelerate, steer, or stop suddenly, unless it's really necessary.

Notes about Reading of This Manual

Please be noted that the descriptions and graphics contained in this manual probably are not applicable for your machine in use.

SAFETY

GENERAL PRECAUTIONS

You are liable to abiding by the safety laws and regulations of relevant departments and fulfilling the operations, checking, and maintenance of machine.

As a matter of fact, all accidents are caused by the non-compliance with basic safety rules and precautions. Most accidents can be avoided by authenticating the potential dangers in advance.

Please read and understand all safety information related to the prevention of accidents. Please ensure to operate the machine only after you have understood how to operate, check, and maintain the machine correctly.

Abiding by All Safety Regulations

- The machine must be operated, checked, and maintained by trained and qualified personnel.
- During the operations, checking, and maintenance of machine, ensure to understand and abide by all rules, regulations, precautions, and safety measures.
- Do not operate, check, or maintain the machine under the adverse influence of alcohol, drug, medicine, or fatigue or under sleepy status.

Upon detection of machine abnormality

During the operations, checking, or maintenance of machine, upon detection of any machine abnormality (Such as noise, vibration, smell, abnormal instrument, smoking or oil leakage, error warning indication, and abnormal display of electric control panel), immediately notify a sales or service dealer and take appropriate measure. Do not operate the machine before the abnormality is solved.

Operating Temperature Range

To maintain the performances and prevent the earlier wear of machine, please abide by the following operating conditions.

- Do not operate the machine when the outside temperature is more than +45°C or less than -15°C
- The operations under +45°C outside temperature will probably result in engine overheating and deteriorated engine performance. In addition, the hydraulic oil will probably become really hot to harm the hydraulic devices.
- The operations under 15°C outside temperature will probably harden the rubber parts (Such as gaskets) and cause earlier wear or damage of machine.
- To operate the machine under the condition beyond above-mentioned outside temperature range, please consult with our service team.

Wearing Appropriate Clothing and Protective Appliances

- Do not wear loose clothing or wear decorative articles that will probably hitch to any joystick or motion part.
- Do not wear oil or fuel contaminated clothing that is easily vulnerable to fire.
- As per the requirements of working environment, wear safety shoes, safety helmet, safety goggles, filtration mask, thick gloves, ear flaps, and other protective appliances. During the use of grinding miller, breaking hammer, or compressed air, please wear appropriate protective appliances, such as safety goggles and filtration mask, as the splashing of metal chippings or other objects will probably cause serious harms.
- Please use the hearing protection devices during the operations of machine.



Exposure to a high noise environment for a long time will result in harm or even complete loss of hearing.



Installation of Fire Extinguisher and First-Aid Kit

Fulfill the preparations for fire and accident.

- Install the fire extinguisher and first-aid kit and learn how to use them.
- Learn how to extinguish fire and handle accident.

- Know how to contact emergency aid and fabricate the emergency contact list.

No Disassembling of Safety Devices

- Please ensure that all guardrails, shelters, and doors are installed properly and securely. Before operating the machine, please repair or replace damaged parts.
- Know how to use safety lock handle, seat belt, and other safety devices and understand the correct operation methods.
- Do not disassemble any safety device, unless for the purpose of checking and repair. Always keep all safety devices under good working condition.

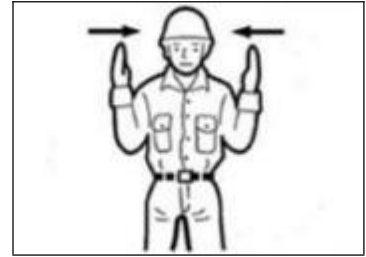

Setup of Signaler and Flagman

Learn how to use the gestures of specific operation needs and designate the person responsible for making gestures.

- All personnel must completely understand all gestures.
- The operator must respond to the gestures of designated person only. However, the operator must abide by the stop gesture made by anyone in all cases.
- The signaler must stand in a clearly visible place while making the gestures.

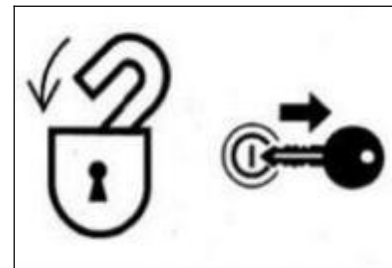

Precautions for Standing up from or Leaving Driver Seat

- Before standing up from the driver seat to open/close windows or disassemble/install the lower window, lower the working device onto the ground, lift up and lock the safety lock handle, and stop the engine.



When the safety lock handle is lowered down (Unlocked), the accidental touch of any joystick will result in sudden movement of machine and cause serious injuries or deaths.

- Please be noted that, even if the safety lock handle is placed at locking position, the bulldozing blade, boom, and auxiliary hydraulic controls can't be locked. Do not touch such controls accidentally.
- While lifting up or lowering down the safety lock handle, take cautions not to touch any joystick. Before leaving the driver seat, lower the working device onto the ground, lift up the safety lock handle to locking position, and stop the engine. Meanwhile, ensure to withdraw the key, close the doors and hoods, and carry the key with you and then preserve it in a designated place.

Guard against Fire and Explosion Dangers

Keep fuel, lubricating oil, grease, and antifreeze away from flame. The fuel is especially inflammable and really dangerous.

Handle these inflammable away from ignited cigarette, match, lighter, and other flame or fire source.

Do not smoke or use open fire while handling fuel or performing the operations of fuel system. Do not leave the operation site while filling fuel or lubricating oil.

Do not disassemble the fuel tank cap or refuel while the engine is running or is not cooled down. In addition, do not splash fuel to any machine hot surface or electronic system part.

Immediately clean the overflowed fuel or lubricating oil thoroughly.

Check for leakage of fuel and lubricating oil. Please eliminate the leaks and clean the machine before operations. Please move the inflammable to a safe place before polishing or welding operations.

Do not cut or weld any pipeline or pipe that probably contains inflammable liquid. Please clean thoroughly by non-inflammable solvent before cutting or welding.

Remove all wastes and impurities from machine. Ensure that there is no oil contaminated rag or other inflammable on the machine.

Handle all solvents and dry chemicals (Foam fire extinguisher) as per the manufacturer's procedures indicated on the containers. Operate in a well-ventilated place.

Never use fuel for cleaning purpose. Always use non-inflammable solvent.

Please open doors and windows for thorough ventilation during the handling of fuel and the cleaning of oil stain or paint. Preserve all inflammable liquids and materials in a safe and well-ventilated place.

The short-circuit of electric system will probably result in fire. Daily check the wire connections for looseness and damage. Re-tighten loose connectors and cable clamps. Repair or replace damaged wires.

- Fire accident caused by pipelines: Ensure that the clamps, protection devices, and cushion pads of hoses and pipes are securely fixed. In event of looseness, the hoses and pipes will be damaged due to vibration or contact with other parts during operations. This will probably result in spray of high pressure oil to cause fire accident or harms.



Toxic Exhaust Gas from Engine

- Do not operate the engine in an enclosed place with poor ventilation.
- If the natural ventilation is not possible, install ventilation fan, fan, extended exhaust pipe, or other ventilation device.

PRECAUTIONS DURING PREPARATIONS

Understanding of working zone

Before starting operations, understand the situation of working zone to ensure safety.

- Check the terrain and ground situation of working zone. For indoor operations, check the building structure and when necessary take safety measures.
- Ensure to keep away from dangers and obstacles such as water ditch, underground pipelines, trees, cliffs, overhead cables, and roads with falling stone or landslide danger.
- Check the positions of underground gas pipelines, water pipelines, and electric cables together with administrator. If necessary, discuss with administrator to determine the detailed safety measures to be taken to ensure safety.
- During operations on road, ensure to take the safety of pedestrians and vehicles into consideration.
- Use a signaler and/or signals.
- Isolate the working zone against the access of non-authorized personnel.
- Before operations in water or driving through shallow rivers, check the water depth, ground firmness, and flow rate in advance.

Understand more operation description information with reference to the “Precautions during Operations”

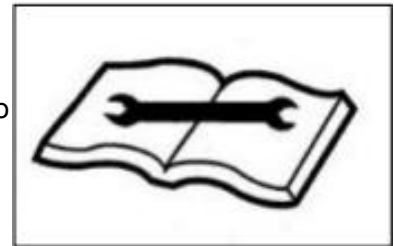

Always Keeping Clean Machine

- Eliminate all loose objects and unnecessary devices in the machine.
- Wipe away lubricating oil, grease, mud, snow, and ice, in order to prevent accident due to slip.
- Remove dusts, lubricating oil, and grease from engine portion to prevent fire accident.
- Clean the area around operator's seat and remove all unnecessary objects from the machine.



Daily Checking and Maintenance

The failure to find out or repair the abnormalities or damages of machine will cause accidents.

- Before operations, fulfill the designated checking and when necessary repair immediately.
 - In event of operation failure due to malfunction or engine malfunction, immediately stop the engine as per stop procedure and park the machine securely, till the malfunction is repaired.
- Precautions within Cab (If installed).
- Before entering the cab, remove the mud and oil/grease from the shoe bottoms.

Operating the machine pedals with shoe bottoms affixed with mud and oil/grease will result in accidents due to slip.

- Do not place any part or tool around the driver seat.
- Do not place any plastic bottle in the cab or install any sucker on window glasses. The plastic bottle or sucker can play a lens role to probably cause fire accident.
- Do not use a mobile phone during traveling or operations.
- Do not bring any inflammable or explosive into cab.
- Do not leave a lighter in the cab. The lighter will probably explode along with the rise of room temperature.



SAFETY MEASURES AT START

Safety measures when starting

Support your body weight by three-point safety posture while getting on/off the machine.

- Do not jump on or off the machine. Do not attempt to get on or off a moving machine.
- Before getting on or off the cab, firstly open the door completely to locking position and check and ensure that the door can't move further (For machine with cab).
- Face towards the machine, get on/off the footplates, and grab the handrail to support your weight by three-point safety posture (Hands and feet).



- Do not use safety lock handle or any joystick as handrail.

Before starting machine, keep all non-authorized personnel away from this zone. Start the engine only after the safe start is confirmed by checking the following items.

- Walk around the machine and alert the repair personnel and the personnel walking around the machine. Start the engine only after it's confirmed that there is no person around the machine.
- Check for warning sign "No Operation" or similar sign affixed on cab door, control, or starter switch. If present, do not start engine or touch any joystick.

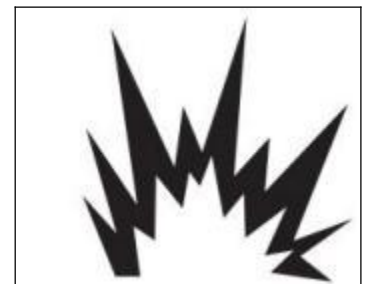

- Sound the horn to alert the personnel around machine.

Sit in the driver seat and start the engine.

- Adjust the seat till it's securely locked.
- Fasten the seat belt.
- Check whether the parking device is actuated and all joysticks and pedals are in neutral.
- Check whether the safety lock handle is at locking position.
- Ensure there is no person near the machine.

- Start and operate the machine only in driver seat.
- Do not attempt to start the engine by short circuiting the terminals of starter device.

Start by Jumper Cable

Start by jumper cable only as per the recommended method. The improper use of jumper cable will result in battery explosion or unexpected machine motions.

After Start of Engine

After the start of engine, fulfill following operations and checking in a place without personnel or obstacle. Upon detection of any malfunction, stop the engine as per the procedure and report malfunction. Warm up the engine and hydraulic oil.

Check all instruments and warning devices for normal functioning. Check for presence of noise.

Test the engine speed control.

Operate all control devices to ensure normal functioning.

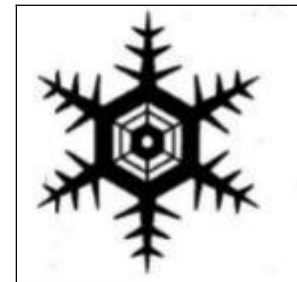

For Cold Weathers

Take cautions that the frozen ground, footplates, and handrails are slip.

Under cold weathers, do not touch any metal part of machine by bare hands. Your skin will be frozen on metal part to cause serious injuries.

Do not use ethyl ether or starting fluid on the engine. The starting fluid can cause explosion and serious injuries or deaths.

Warm up the engine and hydraulic oil.

Operating joysticks without warm-up will result in slow or inappropriate reaction or movement of machine to cause accident.

OPERATION PRECAUTIONS

Guarantee of Good Visibility

Checking of Visibility before Operations of Machine

During operations in a dark place, turn on the working lamp and headlamp of machine and when necessary install additional lighting devices. In event of poor visibility due to severe weathers (Such as fog, snow, rain, and haze), stop the operations of machine till the visibility turns good.

Clean the windows, mirrors, lamps, and camera to keep good visibility. Adjust the mirrors and camera to optimal positions to ensure that the driver sitting in the driver seat can see the rear view (Blind spot).



The non-authorized modification or the installation of non-approved

attachments will probably impair the visibility. The operator's visibility must conform to the requirements of ISO 5006.

Do not carry people on the machine

All personnel are prohibited to sit on any part of machine at any time during traveling Or operations of machine.

Checking for Safe and Reliable Working Zone before Operations

Verify the performance limits of machine.

Set up a signaler at the road shoulders, narrow places, or vision-obstructed places. Do not allow any person to access the turning radius or path of machine.

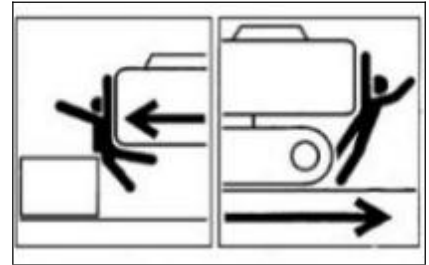

Sound the horn to indicate your movement intention. There are blind zones behind the machine.

Before driving backward, check the safety in the area behind machine and ensure there is no person behind the machine.

Checking of Chassis (Tracks) before Traveling

Before operating the traveling joystick/pedal, ensure that the bulldozing blade is in front of the driver seat.

Please bear in mind that the operation direction of the traveling joystick/pedal with bulldozing blade behind the driver seat is reverse to that with bulldozing blade in front of driver seat.

Safe Traveling

If any part of the body leaves the driver's seat, you must drop the bucket to the ground, or lock the boom safety lever and shut off the engine.

When shoveling materials, the speed should be reduced to below 4KM / h. Working on rough ground, when the bucket is full, slow down as slowly as possible to avoid losing control or even rollover.

During loading operations and transportation, the bucket should be kept as low as possible to keep the driver's view open and keep the machine stable.

Do not move arm steering, otherwise prone to rollover accident.

When shoveling the material, reduce the boom to a minimum, increase the engine speed to a maximum, and then shovel into the material at 2.5 km/h.

In the process of shoveling material operation, when the bucket cutting blade and the bucket teeth encounter obstacles, avoid obstacles, keep the bottom of the bucket level to the ground, and the speed should not be too fast.

Avoid driving over obstacles whenever possible. If it's necessary to drive over obstacles, keep the bucket operating device near the ground and travel at low speed. Do not drive over any obstacle that will incline the machine by 10° or larger.

On rugged roads, drive the machine at low speed and avoid the sudden startup, stop, and direction change. Otherwise, the working device will probably come into contact with the ground to cause unbalance and damage of machine or destruct the structure in surrounding area.

Precautions for Traveling on Slopes

While traveling on slopes, take cautions to prevent the rollover and gliding of machine.

Do not drive the machine on a slope steep enough to cause instability of machine. Please be noted that, in the actual applications, the performances of machine on a slope will be deteriorated due to severe working conditions.

Keep the driver seat facing towards the up slope direction while climbing up a slope. Keep the driver seat facing towards the down slope direction during down slope traveling. In both cases, pay special attention to the ground ahead of the machine during traveling.

While traveling on a slope, lower the bucket to 20~30cm off the ground. While climbing up a steep slope, extend the bucket working device to the front position. In event of an emergency, lower the bucket onto the ground and stop the engine of machine.

When walking on slopes or ramps, drive slowly. Reduce engine speed when going downhill. Do not reverse the machine down a slope.

Do not change direction on slopes or cross slopes. First return to the flat surface, and then take another path.

When walking on a gentle slope covered with grass or dead leaves, or when walking on wet metal plates or frozen ground, the machine may slip. Make sure that the machine does not stop laterally on a slope. If the machine stalls on a slope, return the operating levers to the neutral position, and then restart the engine.

Special Cautions for Operations of Machine on Ice/Snow

While traveling on snowy or icy roads, drive at low speed and avoid the sudden startup, stop, and direction change.

In snowy regions, the road curbs and the roadside objects are buried in the snow to become invisible. In addition, there is a danger of machine rollover or collision with covered objects. Therefore, always operate with cautions.

There is a danger of rollover or snow entrapment while driving the machine into thick snow. Drive with cautions and do not drive over road curbs or entrap in the snow.

For frozen soil surface, the ground becomes soft when the temperature rises, which will probably result in rollover of machine and entrapment of operator in the machine.

If the machine needs to be parked on the slope, a stable pad should be placed below the wheel to prevent the machine from sliding.

No Movement of Bucket over Personnel

Moving the bucket over the personnel has a danger of splashing of loaded material or the sudden falling of bucket.

Guarantee of Driver's Safety during Loading

Do not load before the driver reaches a safe place.

Do not swing or position bucket above personnel or cab. Load from the backdoor of trucks.

Keeping a Safe Distance from Overhead High-Voltage Cables

Never close any part or loaded material of machine to high-voltage cables, unless all safety measures specified by local and national authorities are already taken. There is a danger of electric shock and death when any person approaches to the machine that is discharging electric spark or is near or in contact with power supply.

Always keep a safe spacing between machine and high-voltage cables.

Before starting operations, please verify the relevant operation safety procedures with local power grid.

Consider all electric cables as high-voltage cables. Even if it's known or believed that the power supply is cut off or the cable is clearly grounded, consider such cables also as live cables.

If the machine is too close to high-voltage cables, set up a signaler to sound warnings. Keep all personnel within operation zone away from machine and loaded material.

Pay special attention to the underground high-voltage cables.

Close Observation on Dangerous Working Conditions

Do not operate in any place with falling stone danger.

Keep a safe spacing between machine and edge of digging site. Do not dig the ground ahead of machine.

Do not access any soft ground area. This will probably result in inclination of machine due to dead weight to cause rollover or ground entrapment.

Keep away from unstable ground (Cliffs, road curbs, and deep ditches). If the ground collapses due to machine weight or vibration, there is a possible danger of machine falling or rollover. Please bear in mind that the soil turns infirm after heavy rain or explosion.

The ground on the top of embankment and the ground around and on top of the dug ditches are also infirm.

Do not perform the demolition operations by the impact force of bucket working device. The splashed material fragments and the damaged bucket working device have a danger of serious harms.

Danger during Operations on Slopes

During operations on slopes, slewing or operating the working device can probably result in instability or rollover of machine.

Avoid operations on slopes whenever possible. Leveling operation zone.

If the bucket is fully loaded with material, avoid slewing towards the down slope direction. Otherwise, it will deteriorate the machine stability and probably result in rollover.

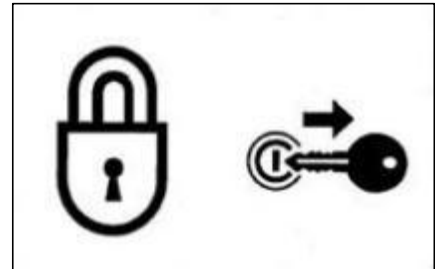

Please pay attention to the objects above your head

During operations under bridges, in tunnels, near cables, or indoors, guard the boom and bucket arm against impact with any overhead object.

Please pay attention to flying objects

This machine is not installed with any protective device to guard the operator against the harms of flying objects. Do not operate this machine in any dangerous place in which the operator is probably subject to the impact of flying objects.

Precautions for Towing

During towing, the improper operations, the incorrect use of rope, or the improper checking will cause serious injuries or deaths.

The breakage or cracking of rope can cause danger. Use wire ropes compatible with the towing force. Do not use any kinked, twisted, or even damaged rope. Do not suddenly apply heavy load onto the rope. Please wear safety gloves during the handling of rope.

Ensure that an operator is assigned each on the towing machine and the towed machine.

PRECAUTIONS FOR PARKING

Safe parking

- Stop the machine on a level, solid, and safe ground. Set the parking device.
- If it's necessary to park the machine or tilt the machine on a slope, securely park the machine and block the machine against movement.

While parking the machine in a street, use gratings, warning signs, or lamps to keep the visible even in the night, in order to prevent the impact with other vehicles.

- Complete the following operations before leaving the machine:

Drop the boom to the ground before leaving the machine. Lift up the safety lock handle to the locking position.

Stop the engine and withdraw the starter key.

Lock the cab and hood and carry the key with you.

PRECAUTIONS DURING TRANSPORT

Safe loading/unlocking of machine

The machine will probably roll over or fall off during loading and unloading. Ensure to take the following safety measures:

Select a solid and level ground and keep a sufficient spacing from the road curb. Fix the ramps of sufficient strength and dimensions to the cargo body of truck. The inclination of the ramps shall not exceed 15°. If the ramps deflect downward excessively, please support the ramps by supports or cushion blocks.

Do not load or unload the machine by working device. Otherwise, it will probably result in rollover or falloff of machine.

Keep the truck cargo body and the ramps clean without oil, sand, ice/snow, or other impurity, in order to prevent the side slip of machine. Clean the tracks.

Block the wheels of transport truck by wedges to prevent movement. While loading or unloading the machine, drive the machine slowly in 1st gear (low speed) as per the signals of the signaller.

Do not change direction on ramps.

Do not slew/swing on ramps. Otherwise the machine will probably roll over.

Slewing (swinging) the machine on the cargo body of truck will probably result in unstable legs of machine. Therefore, operate slowly. If possible, lock the cab doors after loading. Otherwise the cab doors will probably open during the transport.

Plug securely the tracks by wedges and then fix the machine to the truck cargo body securely by ropes or chains.

Safe Lifting of Machine

Master and utilize the correct lifting gestures.

Daily check the lifting device for damaged and missing parts and when necessary replace. Please use the ropes of sufficient capacity for the machine weight during lifting.

Lift the machine as per the procedure described below. Do not operate by any other method, otherwise it will probably result in unbalance of machine.



Do not operate the lifting if there is any operator on the machine.
Operate slowly during lifting to prevent the rollover of machine.
During lifting, keep all personnel away from working zone. Do not move the machine over any person.

Safe Transport of Machine

During the transport of machine, understand and abide by all applicable safety rules, vehicle codes, and traffic regulations. Take the length, width, height, and weight of the transport truck with loaded machine into consideration, in order to select the best transport route.



During the transport, do not start up or stop the transport truck suddenly or drive at high speed. Otherwise, it will result in movement or unbalance of loaded machine.

PRECAUTIONS FOR MAINTENANCE

Warning Information of “No Operation” Sign

During the checking or maintenance of machine, the start of engine or the touch of any joystick by non-authorized personnel will probably result in serious injury accidents.



Before maintenance, please stop the engine and withdraw and carry the key.

Affix warning information “No Operation ” to an eye-catching place such as starter switch and joystick.

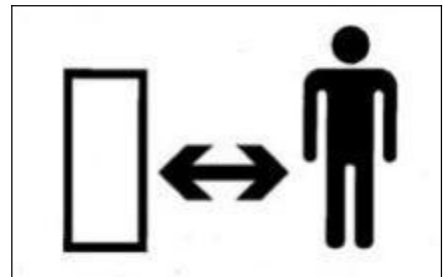

Use of Correct Tools

Do not use any damaged or deteriorated tool or any tool designed for other application. Use tools suitable for related operations.

Periodically Replaced Critical Safety Parts

Replace the fuel hoses periodically. The fuel hoses will wear gradually along with time, even if no wear symptom is visible. Upon detection of any wear symptom, replace the fuel hose, regardless of the replacement schedule. To understand more details.

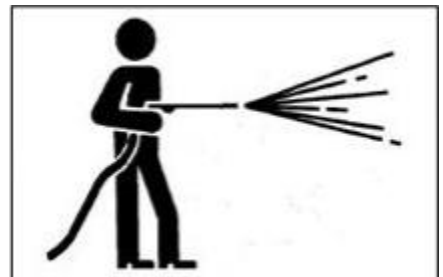

Explosion-Proof Lamps

While checking the fuel, lubricating oil, coolant, and battery electrolyte, please use explosion-proof lamps to prevent fire and explosion. Otherwise, it will probably result in explosion to cause serious injury accidents.

No Access of Non-Authorized Personnel

During operations, the non-authorized personnel are prohibited to access the working zone. Take cautions during grinding, welding, and use of hammer. You will probably be injured by the flying fragments from the machine.

Preparations of Working Zone

Select a stable and level working zone. Ensure the appropriate illumination conditions. For indoor operations, keep well ventilated. Remove obstacles and dangerous goods. Clear slippery areas.



Always Keeping Clean Machine

Please clean the machine before maintenance. Stop the engine before cleaning the machine. Cover the electric parts against water ingress. The water ingress into the electric parts will probably result in short-circuit or malfunction. Do not clean the battery, electronic control units, sensors, connector, or cabby water or steam.



Stop of Engine before Maintenance

While the machine is working or the machine is not working but the engine is running, avoid lubricating or further adjusting the machine.

If the maintenance requires the running of engine, assign two operators for teamwork and keep contact with each other.

One operator must sit in the driver seat to get ready to stop the engine immediately when necessary. This operator must pay special attention not to touch any joystick or pedal, unless it's absolutely necessary.

The other operator for the maintenance must keep the body and clothing away from motion parts of machine.



Keeping Away from Motion Parts

Keep away from all rotating and motion parts. The entanglement of hands or tools into rotating or moving parts will probably cause accidents of serious injuries or even deaths.

The tools or other objects fallen or inserted into the fan or fan belt will be crushed or cut.

Never throw or insert any object into fan or fan belt.

Secure Fixing of Machine and Possibly Falling Parts

Before the maintenance or repairs beneath the machine, lower all movable working devices onto the ground or lowest position and fix the tracks.

If it's necessary to operate beneath the lifted machine or device, always fix by cushion woods, jack, or other firm and stable supports. Do not access the area beneath the machine or working device before it's firmly supported.

This operation is especially important for the hydraulic cylinder operations.



Fixing of Working Device

During the repairs and replacements of bucket teeth or side teeth, to prevent the accidental movement of machine, securely fix the working device.

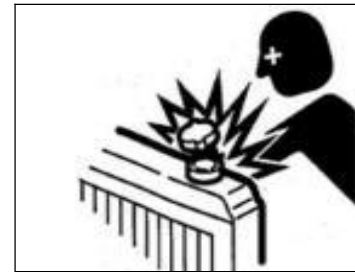

Steady Placement of Opened Engine Hood and Cover

Before operations within the machine, please securely fix the engine hood or machine hood. Keep the engine hood or cover closed under windy weather or while parking the machine on a slope.

Placement of Heavy Weights at Steady Place

If it's necessary to place temporarily heavy weights or attachments onto the ground during disassembling or installation, please ensure to place them in a steady place. Keep the non-authorized personnel away from the place for storage of such objects.

Precautions for Refueling

The smoking and open fire are prohibited during refueling and near the refueling point.

Do not disassemble the fuel tank cap or refuel while the engine is running or is not cooled down. Do not splash fuel to any high temperature surface of machine.

Refuel the fuel tank in a well-ventilated place. Do not top up the fuel tank. Leave an expansion space for the fuel.

Any overflowed fuel shall be wiped away immediately.

Tighten the fuel tank cap securely. If the fuel tank cap is missing, replace with original cap only. The use of non-authorized fuel tank cap with poor ventilation will cause internal pressure in the fuel tank.

Do not use fuel for any cleaning purpose.

Use correct fuel grade based on the season.

Handling of Hoses

The leakage of lubricating oil or fuel can result in fire accident. Do not distort, bend, or impact any hose. Do not use any distorted, bent, or cracked pipeline, metal pipe, or hose, otherwise it will probably result in burst. Re-tighten any loose connector.

Absolution Caution during Handling of High Temperature and High Pressure Parts

Please stop the engine and wait for the machine to cool down before maintenance.

The engine, exhaust pipe, radiator, hydraulic pipes, sliding parts, and many other machine parts are really hot when the engine is just stopped. Touching such parts can cause scalding.

The engine coolant, hydraulic oil, and other fluids are also under high temperature and high pressure status.

Take cautions not to touch the hydraulic oil while loosening engine hood or connector.

Operating the machine under such condition will cause out-spray of hot oil to result in scalding or injuries.

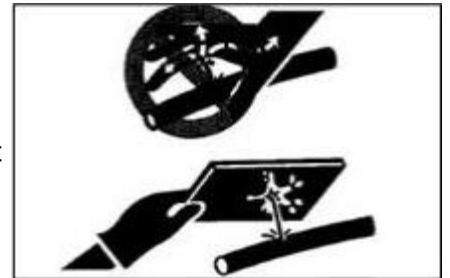

Absolution Caution during Handling of High Temperature and High Pressure Parts

Do not disassemble the radiator cap or drainage plug when the coolant is hot.

Stop the engine and wait for the engine and coolant to cool down.

Slowly loosen the radiator cap to relieve the internal pressure and then take it out.

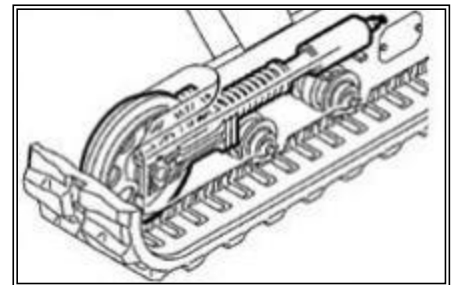

Caution against Internal Oil Pressure

Take caution against internal oil pressure. After the stop of engine, the pressure in the hydraulic oil pipes can hold for a long time.

Before the maintenance, thoroughly relieve the internal pressure.

The high pressure of hydraulic oil can penetrate skin and eyes to cause serious injuries and blindness or even death. Please bear in mind that the hydraulic oil permeating from orifices is nearly invisible to naked eyes. While checking for leakage, wear goggles and thick gloves and protect the skin by paper boards or plywood to protect against the harms of spraying hydraulic oil.

The hydraulic oil penetrating into your skin must be cleared by a doctor familiar with such injuries with surgical method within several hours.

Pressure Relief before Operations of Hydraulic System

Disassembling cap or filter or disconnecting pipeline before the pressure relief of hydraulic system will probably result in out-spray of hydraulic oil.

- Slowly loosen the bleeding plug to relieve the pressure of oil tank.
- While disassembling connector or plug or disconnecting hose, stand on one side, loosen slowly to gradually relieve internal pressure, and then take out.
- The engine oil or oil plug will probably spray out under the internal pressure of traveling motor oil tank. Please slowly loosen the oil plug to relieve the internal pressure.

No Disassembling of Track Pensioner

The track pensioner is installed with a high strength spring. If the track pensioner is disassembled carelessly, the spring will spring out to cause serious injuries. Do not disassemble the track pensioner.

Disconnection of Battery Cables

Please disconnect the battery cables before operations or electric welding of electronic system. Firstly disconnect the negative (-) cable of battery. During reconnection, finally connect the negative (-) cable of battery.

Periodically Replaced Critical Safety Parts

• To guarantee the safe operation of machine for a longer time, add the oil and fulfill the checking and maintenance periodically. To promote the safety, periodically replace the critical safety parts, including hoses and seat belts. To understand more details, please refer to the section “Periodically Replaced Critical Safety Parts”.

• “Periodically replaced critical safety parts” refers to the parts aged, worn, and functionally deteriorated after repeated use. The performances of such parts will change along with time. These characteristics of such parts can cause serious mechanical damages or personal harms and the remaining lives of such parts can't be judged by merely appearance checking or operation hand-feel.



• Upon detection of any visible damage on the appearance, please replace the “periodically replaced critical safety parts”, even if the designated replacement period is not reached.

Asking for Welding Repair

The welding operations, if necessary, must be fulfilled by competent personnel in a working site with complete equipment. To prevent damaging any machine part by over-high current or electric spark, please abide by the following precautions.

- Disconnect the battery cables before electric welding.
- Do not apply 200V or higher voltage continuously.

- Connect the grounding point within 1m reach from the welding area. Do not connect the grounding terminal near the electronic control device/instrument or connector.
 - Ensure there is no seal ring or bearing between welding area and grounding terminal.
 - Do not connect the grounding terminal to the any place near the working device pin or hydraulic cylinder.
 - Before the welding of machine body, disconnect the connector of electronic control device.
- Waste Disposal
- Ensure to collect the drained oil of machine into a container. The improper treatment of waste oil will pollute the environment.
 - While disposing harmful objects, including lubricating oil, fuel, coolant, solvent, filter, and battery, please abide by the applicable laws and regulations.

Disposal of Harmful Chemicals

The direct contact with harmful chemicals will cause serious harms. The harmful chemicals used in this machine include oils/greases, battery electrolyte, coolant, paint, and adhesive. Please dispose the harmful chemicals carefully and properly.

SAFETY SIGNS

To guarantee the safety of operator and operation personnel in the working zone, please set up the following safety signs (markings) at some portions of machine. Walk around the machine with this manual and observe the contents and placement locations of these safety signs. Please review these signs and operation instructions contained in this manual jointly with the machine driver.

- The safety signs shall be clean, clear, and easily legible.



(1)



(2)



(3)

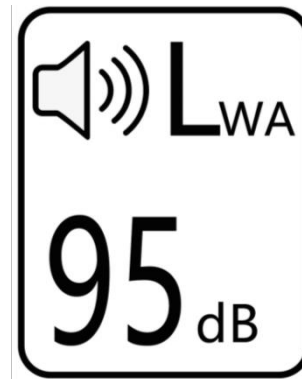
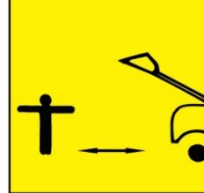
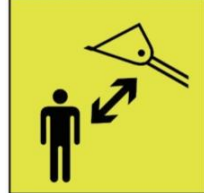

(4)



(5)



(6)

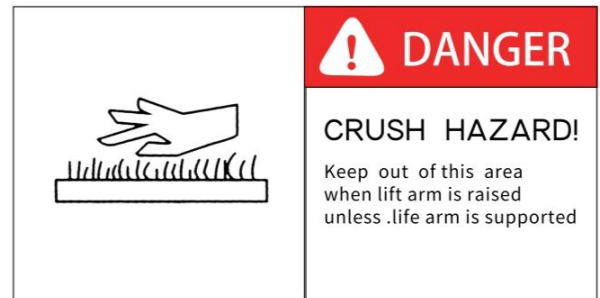

(7)



(8)



(9)

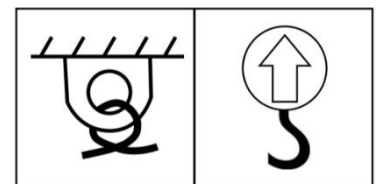

(10)

1. Warning: Carefully read and understand this manual before operating, inspecting, and repairing the machine.
2. Note to knock down: when lowering or raising the boom, knock down
3. Note to fall: Beware of fall, beware of fall
4. Noise prompt: 95 decibels
5. Be careful to squeeze your hands
6. hydraulic oil tank

7. Pay attention to the danger of crushing
8. Pay attention to glove protection
9. Notes for operators
10. The lifting bolt system

CONTROLS

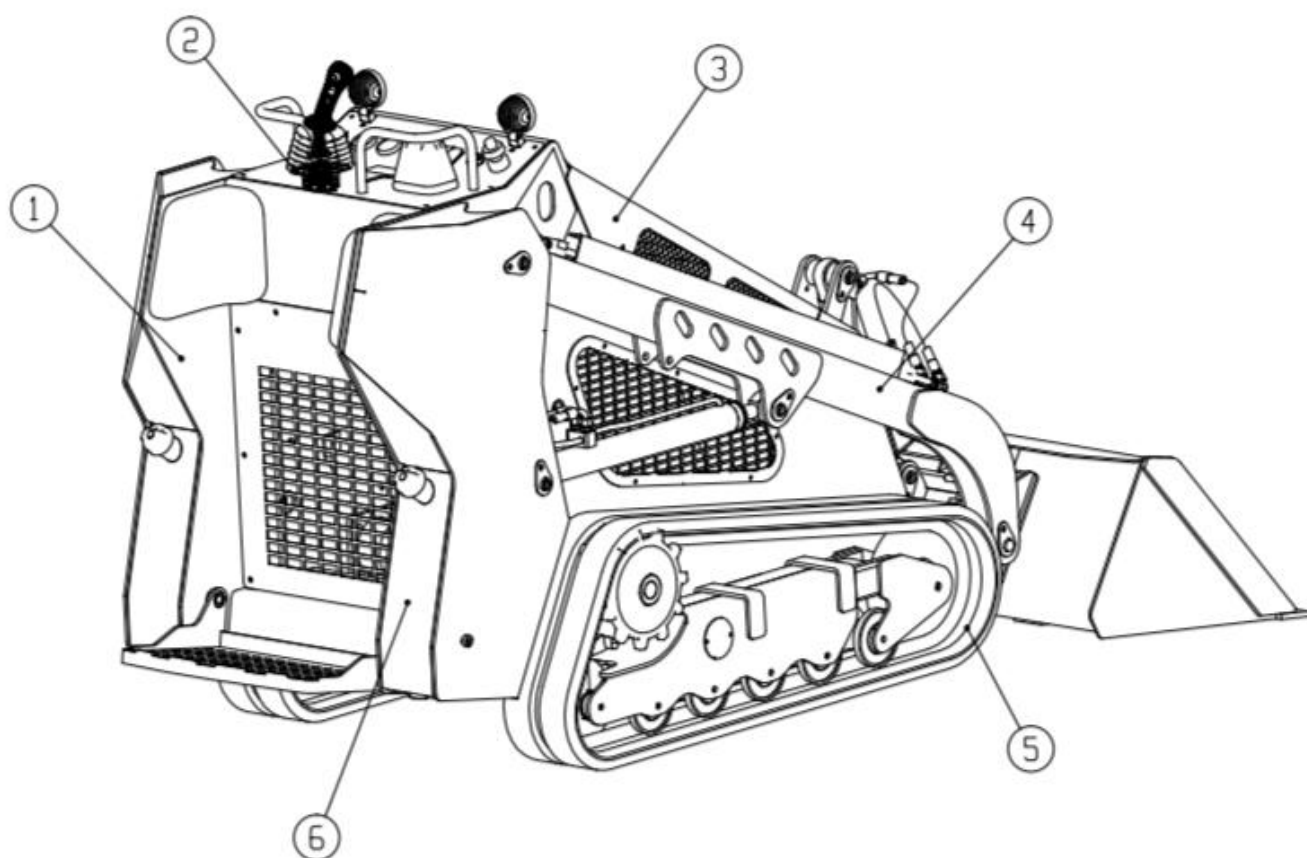

- Main part name:**
Rack assembly
Control panel assembly
Cover assembly
Lift arm assembly
Track assembly
Fuel tank assembly
Engine assembly
Battery assembly
Hydraulic tank assembly

Electrical control panel



	Describe
1	main switch
2	Throttle pull line
3	walking control handle
4	main arm control handle
5	control handle
6	lighting switch

The fuse box

The function of this component is to protect the power system from overflow.
open

1. Insert the hood key and turn it counterclockwise to open the service cover.
2. Lift the engine cover lock and lift the service cover.
3. Find the fuse box.

close

Release the limit lever and close the service cover.

Insert the hood key and turn clockwise to lock the service cover.

Precautions

The instrument has the characteristics of stable performance, simple and elegant. Is an intelligent instrument specially developed for the slip loader. In order to ensure the stability of the data, prolong the service life of the instrument

Life, please take note of the following questions:

1. Do not disassemble the instrument without permission.
2. Never brutally hammer or knock the instrument.
3. Guard against external damages.
4. Keep clean the panel. Any organic solvent or corrosive liquid, including diesel and gasoline, shall be timely wiped away, in order to prevent corroding the panel.
5. Should you have any question during use, please timely contact service personnel.

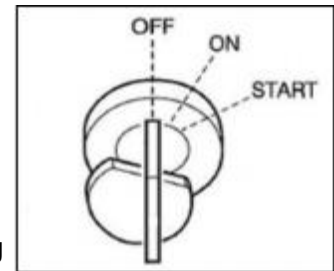

SWITCHES

Starter Switch

Important: Do not rotate the starter key from OFF to ON and then from ON to OFF repeatedly within a short time, otherwise it will probably result in engine malfunction.

OFF This position is used to stop the engine and insert and withdraw the starter key. ON

Engine running position. All electric devices are functional at this position.

START Engine running position. Upon release of key, the switch automatically returns to ON.

Rotate the key to ON and then to START to start the engine.

JOYSTICKS

Accelerator joystick

Control the engine speed, counterclockwise rotation speed increase, clockwise engine speed reduction, It also has a quick throttle function



WARNING

Lift the bucket before operating the driving lever.

Traveling Joystick



WARNING

Walking manipulation handle

Use this control lever to operate the loader. Can move forward or backward, and change direction.

(A) Move the loader in front and back

(B) Place situ loader

The big arm manipulates the handle

Use this bar to lift or lower the bucket height, load and unload the loader.

It is a control handle

The control control handle is used to control the matching control device.

It is a joint

From left to right, there are working oil return port, working oil port A and working oil port B.

To connect the attachment hydraulic line, follow these steps

1. Release the remaining pressure from the system and then bring the handle down the median.

2. Take out the plug.

3. .Connect the genus according to the above figure and requirements.

4. After connecting, fully drain the air from the hydraulic pipe.

a. Start the engine and run at low speed under no-load conditions 10 min.

b. When the engine is running at low idle speed, repeatedly operate the hydraulic hydraulic switch (about 10 times) to discharge the air from the hydraulic pipe.

c. Stop the engine and wait at least 5 min , Until the bubble overflows from the hydraulic oil in the tank Important: If applicable, follow the attached manufacturer's procedure.

5. Check for any oil leakage phenomenon.



A

B

Return
to oil



WARNING

Connect different working tools, pay attention to the connection of the working oil port. For the original shell unloading oil, connect the working oil return interface.

After connection, operate the small engine speed to ensure correct and normal steering and movement to prevent accidents from improper operation and injury to operators.

Disconnecting the line before the hydraulic system may cause the hydraulic oil to bleed

● After the engine stops, immediately move the gear switch several times to release the pressure in the gear hydraulic circuit.

● When disconnecting the hose, stand on the side, slowly loosen, before disassembly, slowly release the internal pressure, these pipes will remain the hydraulic oil used in the hydraulic device.

OPERATIONS

BEFORE START OF OPERATIONS

Getting on/off machine

- Do not jump on or off the machine. Do not attempt to get on or off a moving machine.
- While getting on/off the footplates, hold the handrails to support your body weight and maintain three-point balance posture (Hands and feet) for your body.
- Do not use safety lock handle or any joystick as handrail.

Daily Routine Checking

Before the first start of engine each day, fulfill one walk-around checking.

1. Check whether the parts of the machine are in good condition, whether there is loose, oil leakage and other phenomena.
2. Check whether the power supply, cable and other electrical equipment of the machine are in good condition, for any damage or aging phenomenon.
3. Check whether the hydraulic system of the machine is normal, whether there is oil leakage, damage and other phenomena.
4. Check whether the walking system of the machine meets the requirements, whether there is wear, cracks and other phenomena.
5. Check the cleanliness of the driving control console to ensure that there is no debris and no safety risks.

Total power supply is started

Insert the start switch knob

The switch is switched from the OFF position and rotates clockwise to the ON position.

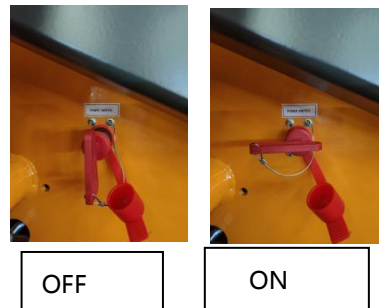

START AND STOP OF ENGINE

1. Adjust the seat to comfortable operating position.
2. Check and ensure that the safety lock handle is at locking position.
3. Check and ensure that all joysticks and pedals are in neutral position.
4. Insert the key into starter switch, rotate to ON position, and then check as below.

Start of Engine



WARNING

- Keep all personnel away from working zone.
- Sound the horn to alert the personnel around machine.

Important: Do not run the starter motor continuously for >15s. If the engine fails to start, wait for 60s and then attempt to restart the engine.

Important: If the engine stops due to shortage of fuel, please add fuel, Running the starter motor for a long time before the supply of sufficient fuel will cause start failure of starter motor.

Slip-shift loader walks

The handle moves forward, and the whole vehicle moves forward;

The handle pushes back and the vehicle pulls back ;

Push the handle to the left and turn left;

The handle pushes to the right and turns left ;

Arm control:

The handle moves forward and moves down ;

The handle pushes backward, and the lifting arm rises;

The handle pushes to the left and the bucket rises ;

The handle pushes to the right, and the bucket hem;

Replacement of the genus : Before replacing the device, the quick lock pin on the lifted plate should be pulled up Rotate 90 degrees and stick firmly on the positioning plate.

For example: place the animal smoothly on a stable plane and adjust the lifting plate To the front tilt state, the upper part is stuck in the genus positioning slot lift up And flip the lifting plate to the inside of the machine, After replacing the device, it is necessary to spin the quick lock pin on the lifting plate Turn 90 degrees to secure the pin shaft in the positioning slot.



Parking



WARNING

- Park the machine on a level, solid, and safe ground. Set the parking device. If it's necessary to park the machine on a slope, block the track by wedges to prevent movement of machine.
- When the safety lock handle is unlocked, the accidental touch of any joystick will result in sudden movement of machine and cause serious injuries or deaths.
- Do not touch such controls accidentally.



CAUTION

Do not stop the machine hastily, unless in event of emergency. Stop the machine at the optimal timing whenever possible.

TRANSPORTATION

LOADING AND UNLOADING



WARNING

The machine will probably roll over or fall off during unloading. Ensure to take the following safety measures:

- Select a solid and level ground and keep a sufficient spacing from the road curb.
- Fix the ramps of sufficient strength and dimensions to the cargo body of truck. The inclination of the ramps shall not exceed 15°. If the ramps deflect downward excessively, please support the ramps by supports or cushion blocks.
- Do not load or unload the machine by working device. Otherwise, it will probably result in rollover or falloff of machine.
- Keep the truck cargo body and the ramps clean without oil, sand, ice/snow, or other impurity, in order to prevent the side slip of machine. Clean the tracks.
- Block the wheels of transport truck by wedges to prevent movement.
- While loading or unloading the machine, drive the machine slowly in 1st gear (low speed) as per the signals of the signaler.
- Do not change direction on ramps.
- Do not slew/swing on ramps. Otherwise the machine will probably roll over.
- Slewing/swinging the machine on the cargo body of truck will probably result in unstable legs of machine. Therefore, operate slowly.
- If possible, lock the cab doors after loading. Otherwise the cab doors will probably open during the transport.
- Plug securely the tracks by wedges and then fix the machine to the truck cargo body securely by ropes or chains.

During the loading or unloading of machine, please ensure to use ramps or platform and abide by following procedures.

1. Securely apply the parking device of transport truck and block the wheels by wedges.
2. Place the ramps securely onto the truck cargo body. The inclination of the ramps shall not exceed 15°.
3. Align the center of truck cargo body with the center of machine and align the center of ramps with center of tracks.
4. Lower the bucket working device as low as possible and take cautions not to impact it with the transport truck.
5. Reduce engine speed.
6. According to the signaler's signals, drive the machine straightly up or down along the ramps in 1st gear (low speed).

7. Load the machine to designated position of transport truck. Refer to “Transport Status” in page 55 for details.

LIFTING OF MACHINE



WARNING

- Master and use the correct lifting signals.
- Daily check the lifting device for damaged and missing parts and when necessary replace.
- Please use the ropes of sufficient capacity for the machine weight during lifting.
- Lift the machine as per the procedure described below. Do not operate by any other method. This is really dangerous as it will probably result in imbalance of machine.
- Do not operate the lifting if there is any operator on the machine.
- Operate slowly during lifting to prevent the rollover of machine.
- During lifting, keep all personnel away from working zone. Do not move the machine over any person.

Important: This lifting method is applicable for the models with standard overall parameters. The gravity center varies depending on the installed attachments and optional devices.

Lifting

Lifting process

1. Raise the bucket to be slightly off the ground and adjust the operating handle to the neutral position.
2. Stop the engine, retrieve the starter key, and then leave the machine.
3. Install the rope according to the lifting mark on the machine. When lifting the equipment, the site personnel should pay attention to stay away from the machine.
4. Lift the machine slowly until it leaves the ground.
5. Stop lifting until the machine stabilizes and then lift the machine.
6. After reaching the machine position, put down slowly and notice the machine not to rotate and shake.
7. After stabilizing the machine, then withdraw the lifting rope.

MAINTENANCE

OVERVIEW

Maintenance Overview

To maintain the good status and long-term serviceability of the machine, please fulfill the checking and maintenance correctly and safely abide by the procedures recommended by this manual.

Based on the total operating time of the machine, the checking and maintenance items can be divided into several groups: Every 10h (Walk-around checking and daily routine checking), every 50h, and every 250h. Please refer to the reading of hour meter to determine the checking and maintenance timing.

The items for which the checking and maintenance intervals can't be determined are listed in column "As necessary".

When the machine is operated in extremely severe environment (Dusty or high temperature environment), fulfill the checking and maintenance ahead of the periods specified by maintenance schedule.

Maintenance Precautions

Do not fulfill any other checking or maintenance item not listed in this manual.

For the items not listed in this manual, please ask your sales or service dealer for help.

Keeping Machine Clean

- Clean the machine before checking and maintenance. Keep the machine clean.
- Stop the engine before cleaning the machine. Cover the electric parts against water ingress. The water ingress into the electric parts will probably result in short-circuit or malfunction. Do not clean the battery, electronic control units, sensors, connector, or operating room by water or steam.

Fuel, Lubricating Oils, and Greases

- Select fuel, lubricating oils, and greases as per the "Fuel and Lubricant Table".
- Use the water-free fuel, lubricating oil, and grease. Take cautions to eliminate the ingress of dusts during replacement or filling of fuel, lubricating oil, and grease.
- Store the fuel, lubricating oil, and grease in designated location and guard against the ingress of water and dusts.

Precautions for Refueling

- If the fuel filler port is installed with a filter screen, do not remove the filter screen during refueling.
- Please ensure to tighten the fuel tank cap after refueling.
- The refueled volume shall not exceed the designated fuel volume.

No Cleaning of Engine Parts by Fuel

It's prohibited to clean engine parts by fuel. Use non-inflammable detergent.

Guard against Ingress of Dusts

The installation and disassembling of parts shall be operated in a dust-free place. Clean the working area and clean the parts to guard against ingress of dusts.

Cleaning of Mounting Surfaces

Keep clean the contact surface of parts during the installation and disassembling. If the sealing grooves of the contact surfaces are damaged, please contact your sales or service dealer for repairs or breakup.

SERVICE DATA

Fuel and Lubricant Table

Please refer to following table to select appropriate fuel, lubricating oil, and grease based on the temperature.

- Regardless of the specified periods, replace the oil when the oil is too dirty or already deteriorated.
- Never mix the oils of different trademarks while adding fuel/oil. To replace with fuel/oil of other trademark, please replace completely.

Fuel

Specified fuel

ISO 8217 DMA

ASTM D 975 Level: NO 1-D or 2-DGB/T 252-1994Light diesel oil, summer with 0 # winter use-10#-20#-30# .

Note: The diesel grade is based on the tipping point: some levels of diesel are poorly liquid at low temperatures. Please choose correctly according to the ambient temperature

Diesel type		
ambient temperature	GB/T 252	ASTM D975
-5°C Or higher	-10#	level2-D
-15°C Or higher	-20#	level1-D
-25°C Or higher	-30#	



WARNING

If the fuel specification used is incorrect, it may cause the engine performance to decline and part failure.

Use clean containers to store the fuel oil.

Store the fuel in a clean bucket beyond the rain. Once the fuel is mixed with water or dirt can cause engine failure.

Hold the tank for 24 hours until the water and dirt in the fuel settle at the bottom of the container. Pump the clean fuel from the upper part of the container.

Lubricant



WARNING

If the lubricating oil used is not correct, it may cause the engine parts to bite or wear prematurely, thus shortening the service life of the engine.

(1)lubricating oil specification:

CF or CH lubricants for API classification.

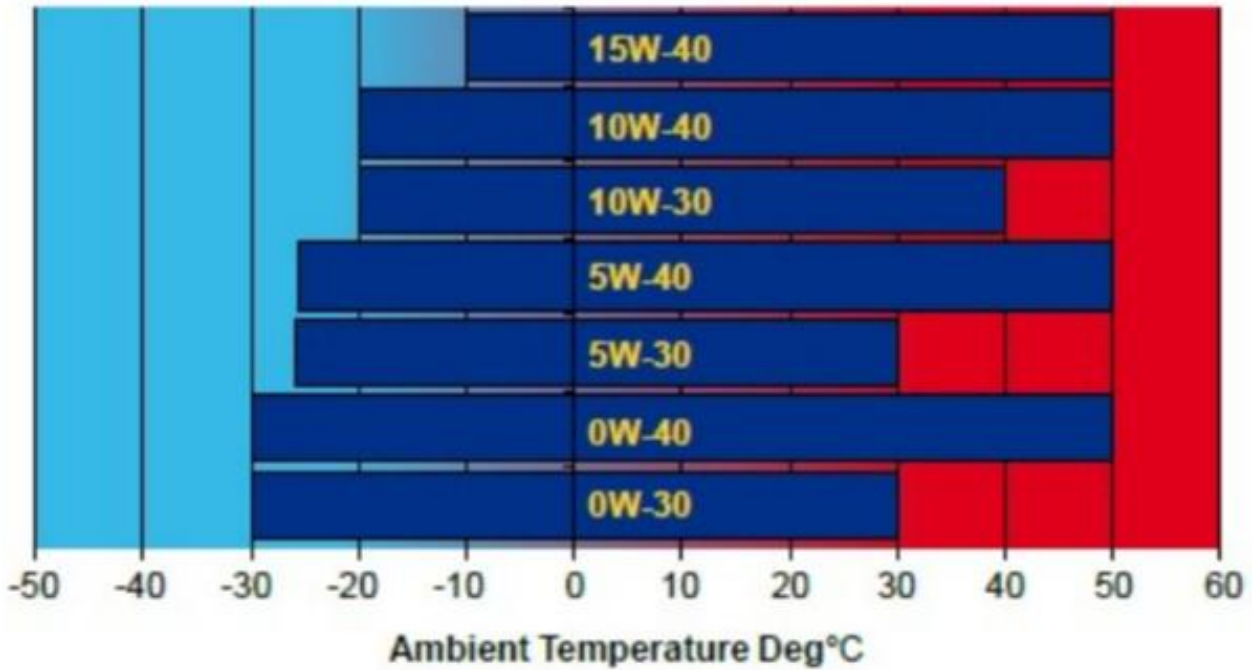

Recommended oil: Use oil per API CH-4 / ACEA E5. Select the lubricating oil with the correct viscosity according to the ambient temperature.

! WARNING

If the lubricating oil used is not correct, it may cause the engine parts to bite or wear prematurely, thus shortening the service life of the engine.

Use lubricating oil Store and use lubricants carefully to prevent dirt or dust from coming into the oil.

When filling the lubricating oil, please clean the area around the refueling port.

Do not mix different specifications of lubricating oil to prevent the negative impact on lubrication performance.

Periodical Replacement of Hydraulic Oil

With installed hydraulic breaking hammer, the hydraulic oil deteriorates faster than the common digging operations. Ensure to replace the hydraulic oil and oil return filter element.

- The failure to replace timely will result in damage of machine and breaking hammer hydraulic system. To prolong the lives of hydraulic devices, please timely replace the hydraulic oil and oil return filter element as per the table below.
- During the replacement of hydraulic oil, clean the oil suction filter screen.

Replacement period (Hour)

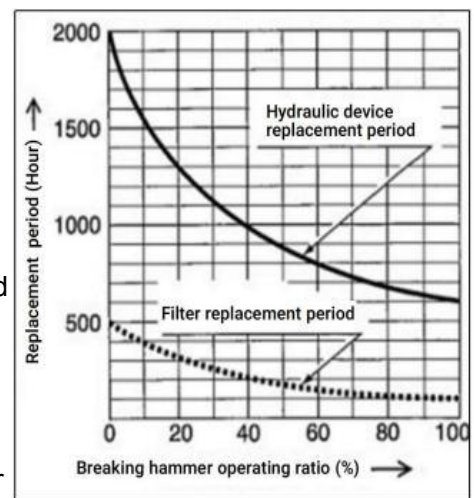

(): For the use of common anti-wear

Item	Hydraulic oil	Filter element
1 st time	--	25

2 nd time	--	100
Periodic	1200(600)	200

By taking the breaking hammer operating ratio of 100% for instance. Refer to “Hydraulic Breaking Hammer” in page 91 for details.

List of Wearing Parts

Periodically replace the wearing parts, including filters and filter elements, as per the table below.

System	Item	Part name	Replacement period
Hydraulic system	Ventilator		Every 1000h
Engine lubrication system	Engine oil filter	Filter cartridge	Replace after first 50 hours, then every 250 hours
Fuel system	Fuel filter	Filter cartridge	Every 250h
Air filter system	Air filter	Primary (Outer) filter element	Every 1,000h or 6 cleaning cycles (Whichever comes first)
		Secondary (Inner) filter element	At replacement of primary filter element

CRITICAL SAFETY PARTS

To operate the machine safely, please fulfill the periodical checking and maintenance. The following critical safety parts shall be replaced periodically to improve safety. These parts can cause serious injuries or fire accident if they are damaged.

List of Critical Safety Parts

body	Replace the key safety parts regularly	Replacement cycle
fuel system	fuel line	Every 2 years
	Packaging on the fuel tank lid	
Heatb booster	heater hose	
Coolant system	Rubber hose	
Hydraulic system	Hydraulic pipeline	
	Safety belt	Every 3 years
	antiskid plate	

The materials of the above-mentioned critical safety parts will deteriorate along with time to cause wear or deteriorated performance. It's difficult to determine the deterioration extent during periodical

checking. Therefore, such parts shall be replaced with new ones to guarantee stable performance, even if such parts are still working well. Please be noted that, regardless of the replacement schedule, any part with wear symptom must be replaced immediately. Upon detection of any deformed or cracked pipe clamp, immediately replace it together with hose. Please consult with your sales or service dealer for the replacement of safety parts.

Except the critical safety parts, check and tighten the hydraulic pipes and when necessary replace.

During the replacement of hydraulic pipes, replace the O-ring and seal ring as well.

Check the fuel and hydraulic pipes as per the schedule specified by the following table.

Checking type	Checking item
Daily routine checking	Leakage of hydraulic or fuel pipe connector
Monthly checking	Leakage of hydraulic or fuel pipe connector Damage (Cracking, wear, and tear) of hydraulic or fuel pipe
Yearly checking	Leakage of hydraulic or fuel pipe connector Aging, distortion, and damage (Cracking, wear, and tear) of hydraulic or fuel pipe and/or status of hose in contact with other machine parts



notice

If repair or repair is required, consult your agent or distributor.

Opening of engine hood and machine hood for checking

1. Check for presence of branches, leaves, oil, and other inflammable around the engine and battery.
2. Check for presence of lubricating oil and coolant leakages around the engine.
3. Check hydraulic oil pipes, hydraulic devices, hoses, and connectors for oil leakage.

Walk-around checking of machine

1. Check lamps for presence of dusts and damages and check lamp bulbs for burnout.
2. Check hydraulic accessories and hoses for damage.
3. Check bucket, bucket teeth, and side teeth for wear, damage, and looseness.
4. Check hook, anti-slip stop block, and hook seat on bucket for presence of damage. (Optional)
5. Check handrails, footplates, and anti-slip surfaces for damage and check for any loose bolt.
6. Check tracks and track shoes for presence of slip, check track carrier rollers, idling device, and sprocket for presence of damage and wear, and check for loose bolt.
7. Check traveling motor for oil leakage.
8. Check shelter and guard plates for damage and check for loose nuts and bolts.
9. Check exterior and interior rear view mirrors for contamination and damage and when necessary adjust.
10. Check labels for presence of dusts and damage.

TROUBLESHOOTING

NO BATTERY POWER

The following symptoms indicate no battery power.

- No rotation of starter motor or start failure of engine.
- Low volume of horn.

Remedy procedure

Start the engine by the booster battery on other machine (booster machine) and jumper cable.



WARNING

- To start the engine by jumper cable, ensure to connect the cable by correct procedure. The improper use of jumper cable will result in battery explosion or unexpected machine motions.
- The booster machine and the machine with depleted battery are prohibited for mutual contact.
- The positive (+) and negative (-) clamps of the jumper cable are prohibited for mutual contact.
- During connection, firstly connect the jumper cable to positive (+) terminal. During disconnection, firstly disconnect the cable from negative (-) terminal.
- Connect the last clamp of jumper cable to a point as far as possible from the battery.

Cable to Start Engine.

Important: The jumper cable and clamps in use shall be suitable to the battery capacity. Do not use any damaged or corroded jumper cable or clamp.

Important: Ensure the same capacity for the battery on the rescue machine and the battery on malfunctioned machine. **Important:** Ensure to connect the cable clamps securely.

Connection of Jumper Cable

Important: Place the starter keys of both rescue machine and malfunctioned machine to OFF.

1. Connect a clamp of jumper cable (R) to the positive (+) pole of malfunctioned machine.
 2. Connect the other jumper cable clamp (R) to the booster (+).
 3. Connect the jumper cable clamp (B) to the charger (-).
- Always wear goggles while using jumper
4. Connect the other clamp of jumper cable (B) to the engine support of the malfunctioned machine. Connect the clamp to a point as far as possible from the battery.

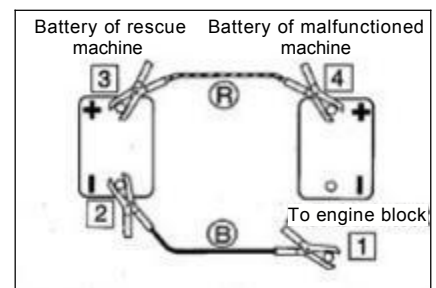
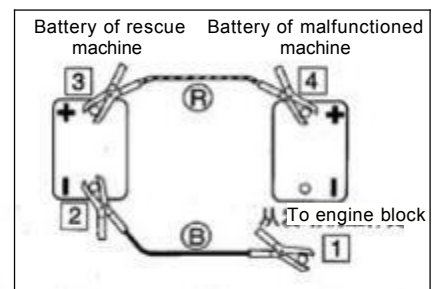

After Start of Engine

1. Check and ensure that the wire clamps are already connected securely to various terminals.
2. Start the engine of rescue machine and run it at high speed.
3. Start the engine of the malfunctioned machine.

Disconnection of Jumper Cable

After the successful start of the engine of malfunctioned machine, disconnect the jumper cable in reverse sequence of the connection procedure.

1. Disconnect the clamp of jumper cable (B) from the engine support of malfunctioned machine.
2. Disconnect the other jumper cable (B) from the charger (-).
3. Disconnect the jumper cable (R) clamp from the charger (+).
4. Disconnect the jumper cable clamp (R) from the uncharged machine (+).

Recharging

Please ask our service team to recharge the depleted battery.

PARAMETERS

BASIC PARAMETERS

performance parameter			
	model		680
performance	burden rating	kg	780
	Shovel bucket volume	m ³	0.2
	Maximum lift	kg	1200
	Working speed	km/h	0~5.8
	rated pressure	Mpa	17
	Raise the time	s	4.1
	Drop-out time	s	2.4
	Fold time	s	1.5
	climbing capacity	%	30
	working weight	kg	1380
	engine	brand	
model			D1105
mold			Diesel engine, water-cooled, three-cylinders
output power			18.2kW/3000rpm
torque			70.4Nm/2200rpm
Engine oil		L	5.1
hydraulic pressure	hydraulic pump		Italy PWG/Bondioi&Pavesi

system	Hydraulic motor		Denmark Danfoss
	valve		Italy Hydrocontrol
	Auxiliary system pressure	bar	170
	Auxiliary system flow	L/min	43
capacity	fuel tank	L	35
	Hydraulic oil tank	L	25

All ratings of the machine are obtained when the machine is operating on a solid horizontal support surface. If the working environment conditions of the machine differ from the above-mentioned reference conditions (Such as the operations on uneven ground and slope), the operator shall take these conditions into consideration.

OVERALL DIMENSIONS OF MACHINE

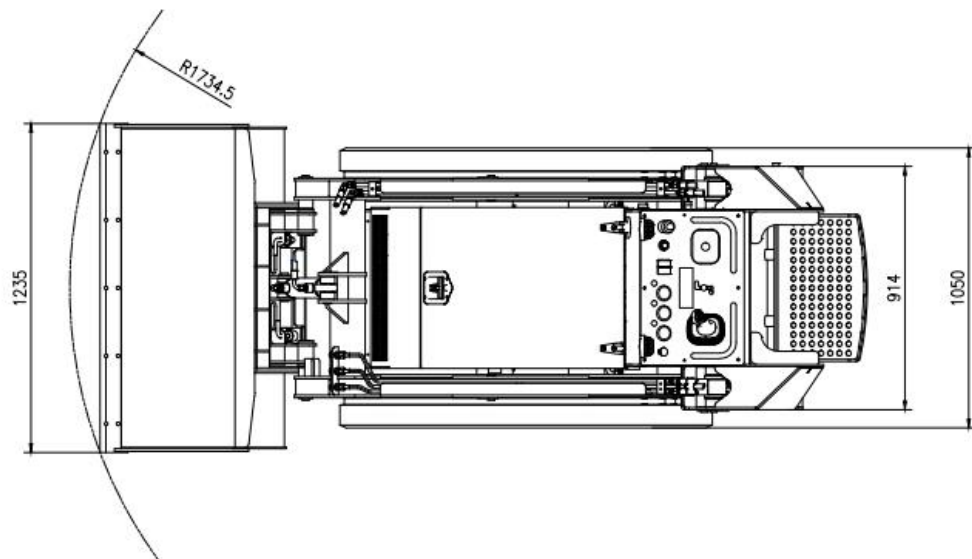
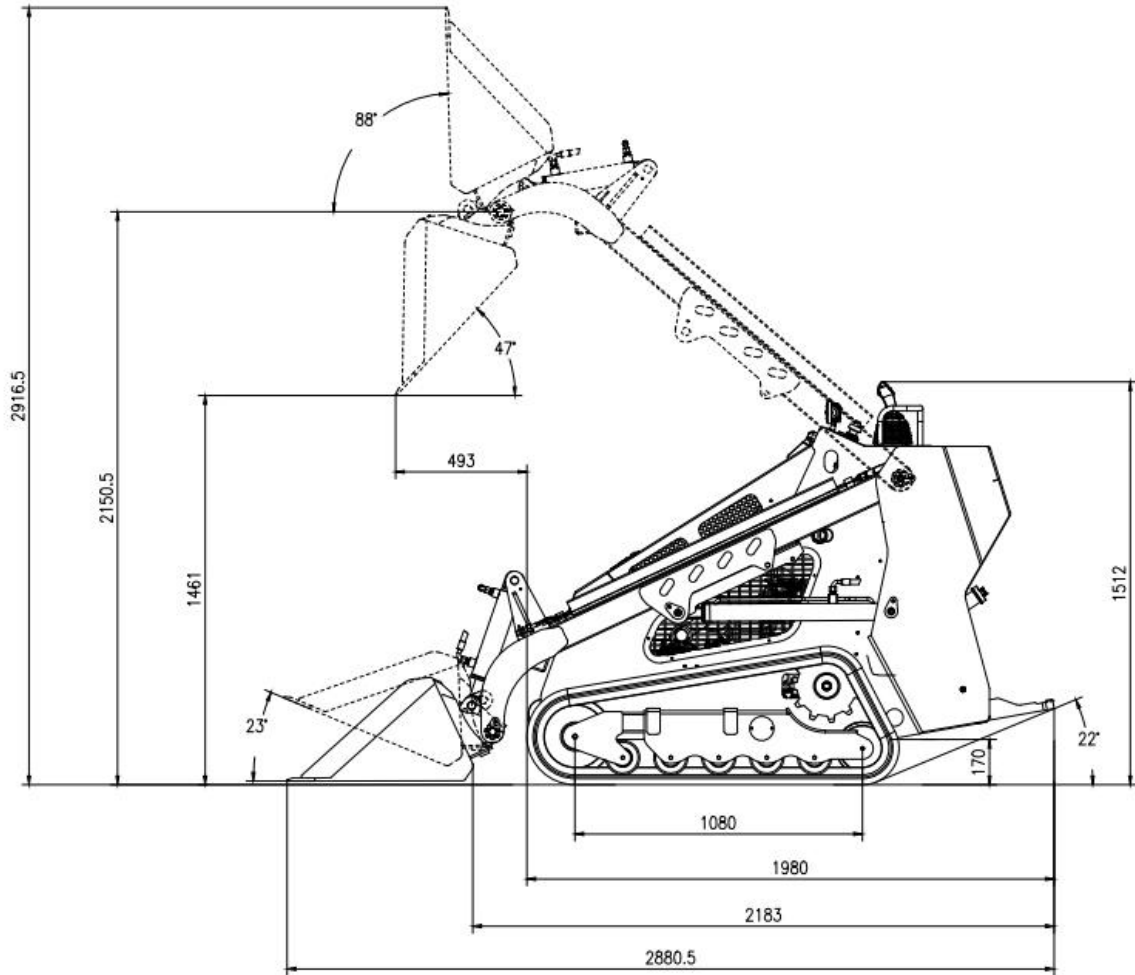

EXPLODED VIEW & PARTS LIST

Exploded View

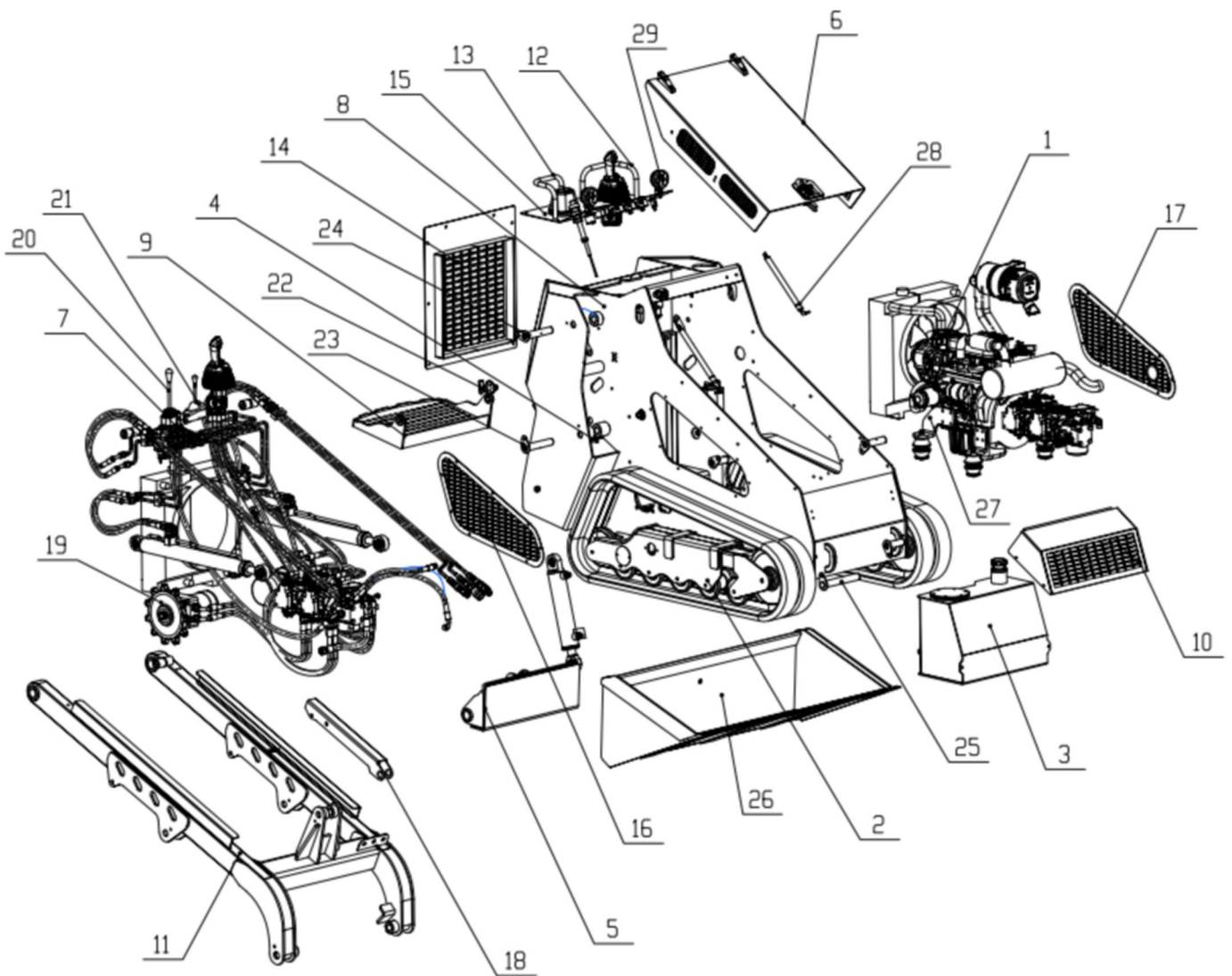

Parts list :

No	Part No	Description	Q'ty	Remark
1	680BF000-1	Engine assembly	1	
2	680BF000-2	Walking assembly	1	
3	680BF000-3	Hydraulic tank assembly	1	
4	680BF000-4	Fuel tank assembly	1	
5	680BF000-5	Lift plate assembly	1	
6	680BF000-6	Upper shroud assembly	1	
7	680BF000-7	Hydraulic system assembly	1	
8	680BF000-8	Rack welded assembly	1	
9	680BF000-9	Foot pedals	1	
10	680BF000-10	Front mounting shroud assembly	1	
11	680BF000-11	Lifting arm assembly	1	
12	680BF000-12	Left armrest assembly	1	
13	680BF000-13	Right armrest assembly	1	
14	680BF000-14	Radiator baffle	1	
15	680BF000-15	Operator panel assembly	1	
16	680BF000-16	Right side cover	1	
17	680BF000-17	Left side cover	1	
18	680BF000-18	Boom limit plate	1	
19	680BF000-19	Drive wheels	2	
20	680BF000-20	Triple control valve	1	M45/3
21	680BF000-21	Commutation plates	1	
22	680BF000-22	Battery switch	1	300A
23	680BF000-23	Pin shaft	2	L=160
24	680BF000-24	Pin shaft	2	L=160
25	680BF000-25	Pin shaft	2	L=215
26	680BF000-26	Shovel hopper assembly	1	
27	680BF000-27	Right rear support plate	1	
28	680BF000-28	Gas springs	2	L=600,150N
29	680BF000-29	LED lighting	2	2-18W

Engine assembly explosion diagram

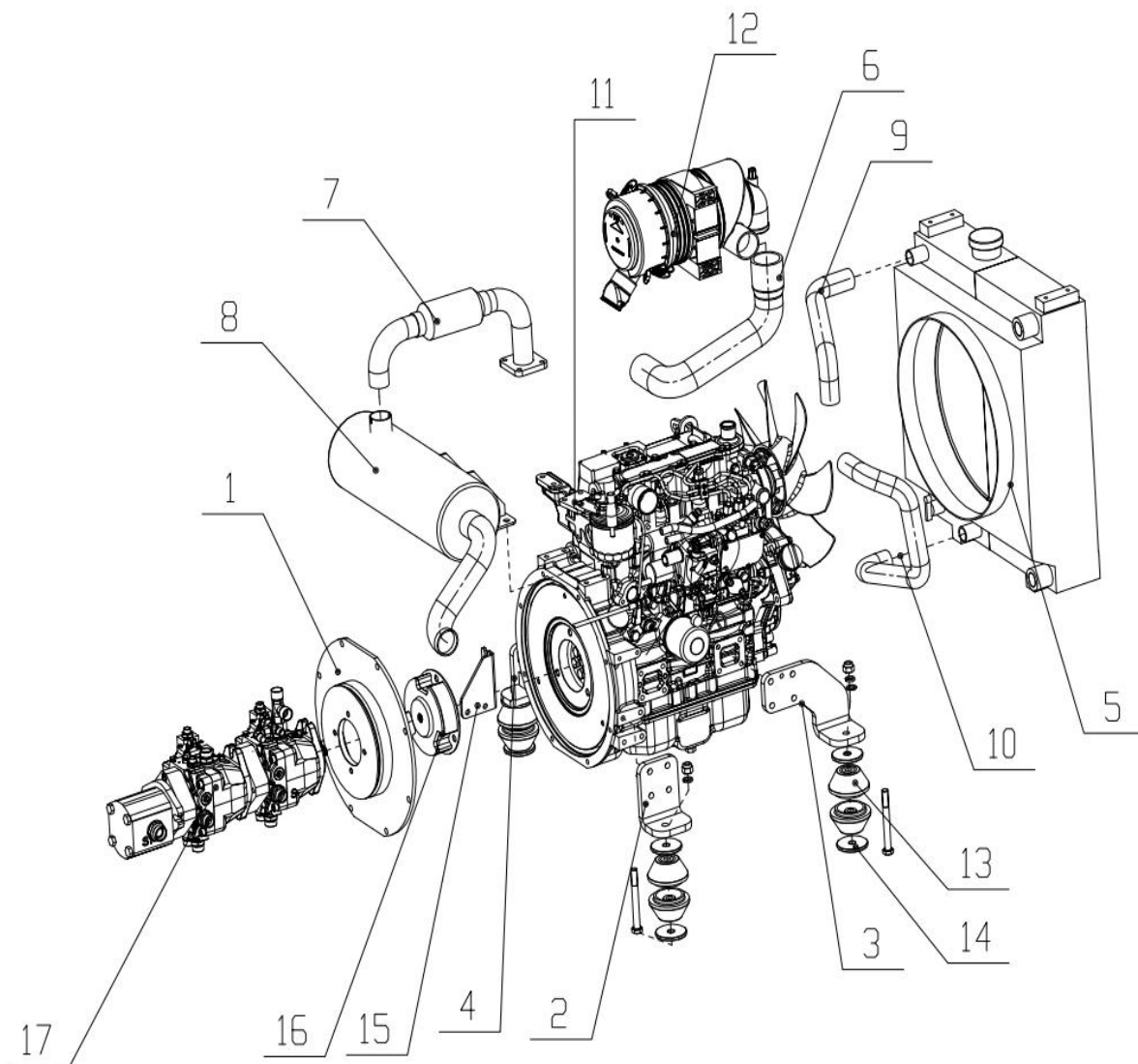

List of parts:

No	Part No	Description	Q'ty	Remark
1	680BF001-1	Pump seat	1	
2	680BF001-2	Left front support plate	1	
3	680BF001-3	Right rear support plate	1	
4	680BF001-4	Right front support plate	1	
5	680BF001-5	radiator	1	
6	680BF001-6	Air filter tubes	1	
7	680BF001-7	Smoke extractor assembly	1	
8	680BF001-8	muffler	1	
9	680BF001-9	Outlet pipes	1	
10	680BF001-10	Return pipes	1	
11	680BF001-11	Fine filtration fixing plate	1	
12	680BF001-12	Air filter assembly	1	
13	680BF001-13	Shock absorber assembly	1	
14	680BF001-14	Shock absorber flat pads	1	
15	680BF001-15	Throttle retention plate	1	
16	680BF001-16	Coupling	1	
17	680BF001-17	Hydraulic pumps	1	

Walking assembly explosion diagram

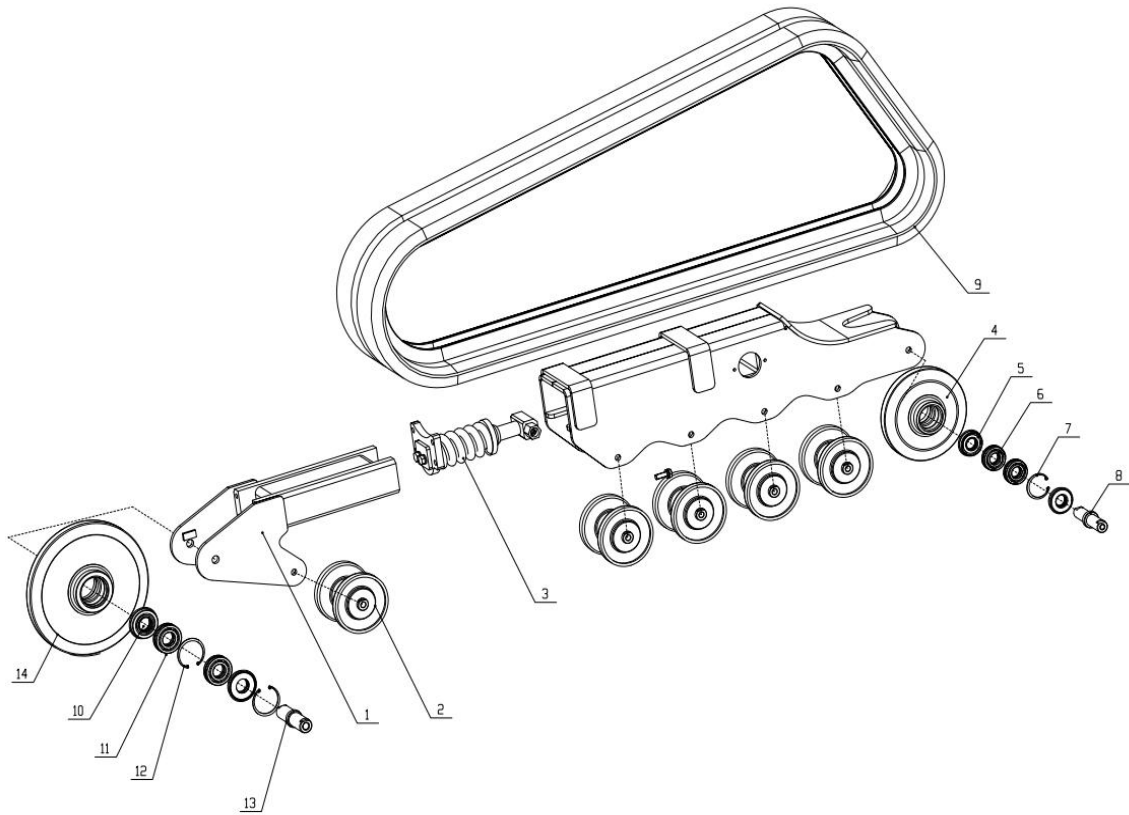

零件清单：

No	Part No	Description	Q'ty	Remark
1	680BF002-1	Track tensioner	2	
2	680BF002-2	Rollers	10	TY105
3	680BF002-3	Tension assembly	2	
4	680BF002-4	Guide wheel assembly	2	
5	680BF002-5	Deep groove ball bearings	4	6205-zz
6	680BF002-6	Oil seals	4	∅ 25*∅ 52*13/∅ 58*3.5
7	680BF002-7	Retaining rings for holes	4	∅ 52
8	680BF002-8	Guide axles	2	
9	680BF002-9	Rubber tracks	2	200-72-44
10	680BF002-10	Deep groove ball bearings	4	6206-zz
11	680BF002-11	Oil seals	4	∅ 30*∅ 62*11/∅ 70*3
12	680BF002-12	Retaining rings for holes	4	∅ 62
13	680BF002-13	Tension the axle	2	
14	680BF002-14	Tensioner assembly	2	

Explosion diagram of the hydraulic fuel tank assembly

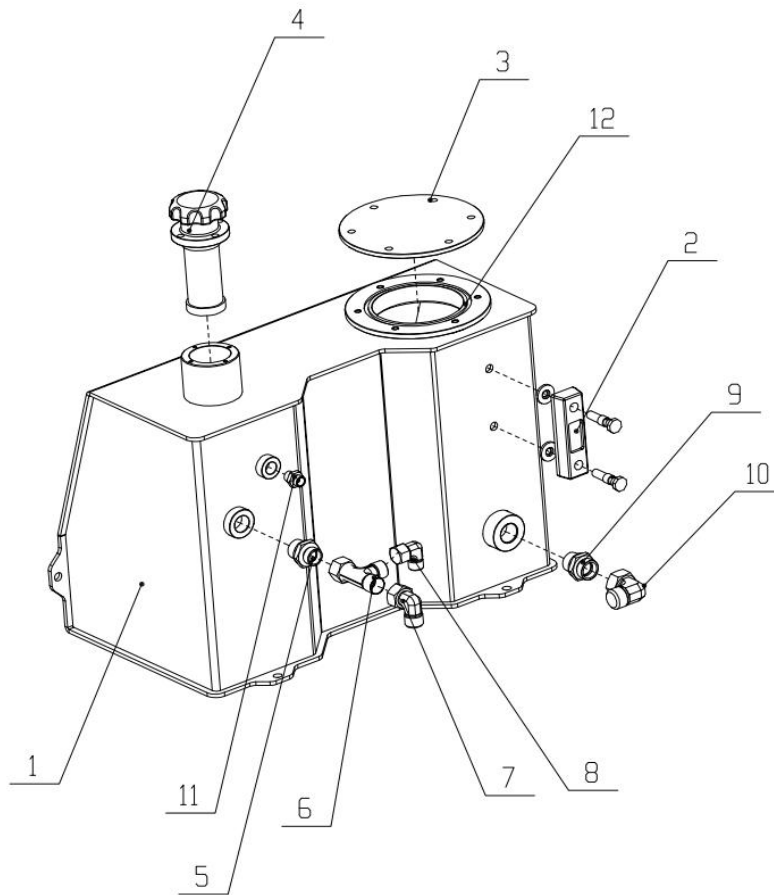

Parts list :

No	Part No	Description	Q'ty	Remark
1	680BF003-1	Hydraulic tanks	1	
2	680BF003-2	Oil level gauge	1	YWZ-80
3	680BF003-3	Wash the cover	1	
4	680BF003-4	Air filter	1	EF2-32
5	680BF003-5	Hydraulic connectors	1	GE15L/M22*1.5EDOMDA3C
6	680BF003-6	Hydraulic connectors	1	EL15LA3CX
7	680BF003-7	Hydraulic connectors	1	EL15LA3CX
8	680BF003-8	Hydraulic connectors	1	EL15LA3CX
9	680BF003-9	Hydraulic connectors	1	GE18L/M26*1.5EDOMDA3C
10	680BF003-10	Hydraulic connectors	1	EW18LA3CX
11	680BF003-11	Hydraulic connectors	1	GE08L/M16*1.5EDOMDA3C
12	680BF003-12	O-rings	1	∅ 120*3.55

Fuel tank assembly explosion diagram

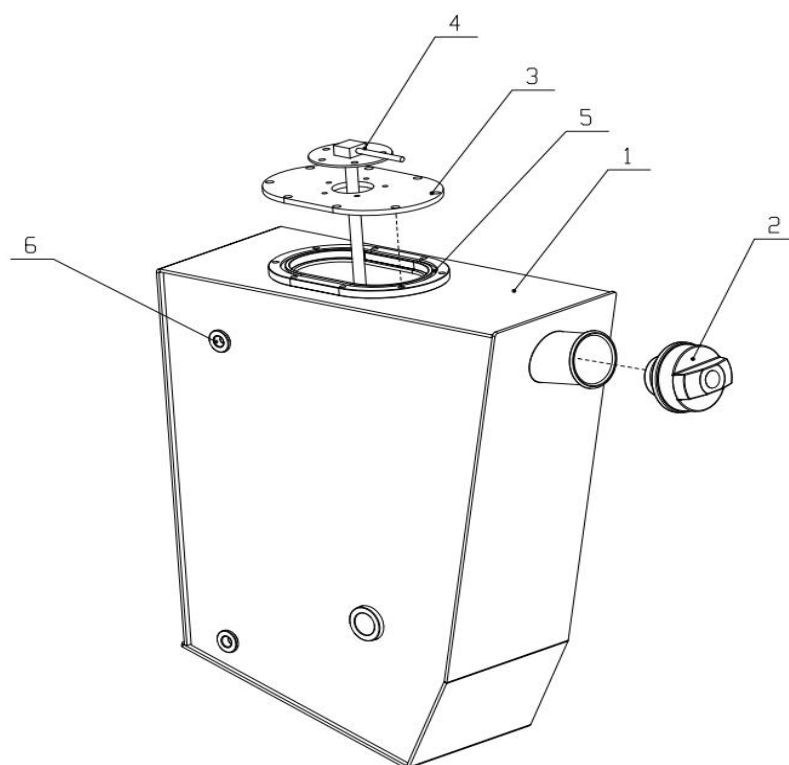

Parts list :

No	Part No	Description	Q'ty	Remark
1	680BF004-1	Fuel tanks	1	
2	680BF004-2	Fuel tank cap	1	M45
3	680BF004-3	Right side cover	1	
4	680BF004-4	Liquid level sensors	1	L=380
5	680BF004-5	O-rings	1	∅ 120*3.55
6	680BF004-6	Pagoda joints	2	∅ 8-G1/4

Explosion diagram of the lifting plate assembly

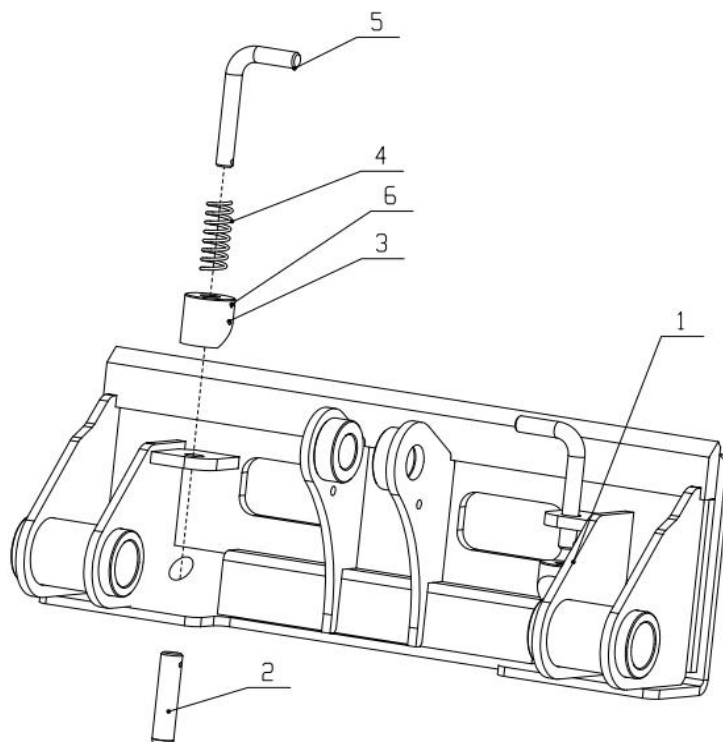

Parts list :

No	Part No	Description	Q'ty	Remark
1	680BF005-1	Lifting support plate assembly	1	
2	680BF005-2	Bucket pins	2	
3	680BF005-3	Pin limit block	2	
4	680BF005-4	Compression springs	2	
5	680BF005-5	Lift bars	2	
6	680BF005-6	Elastic cylindrical pins	4	∅4*35

Explosion diagram of the upper shield assembly

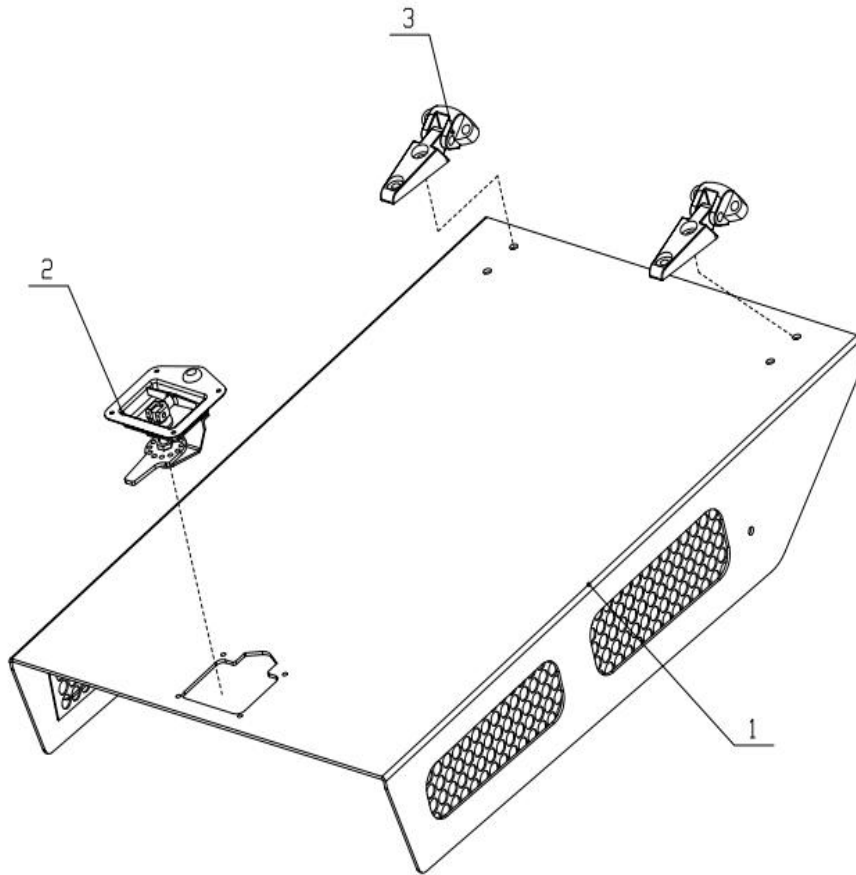

Parts list :

No	Part No	Description	Q'ty	Remark
1	680BF006-1	Upper hood assembly	1	
2	680BF006-2	Panel locks	1	MS758
3	680BF006-3	Panel hinges	2	

Explosion diagram of the hydraulic system assembly

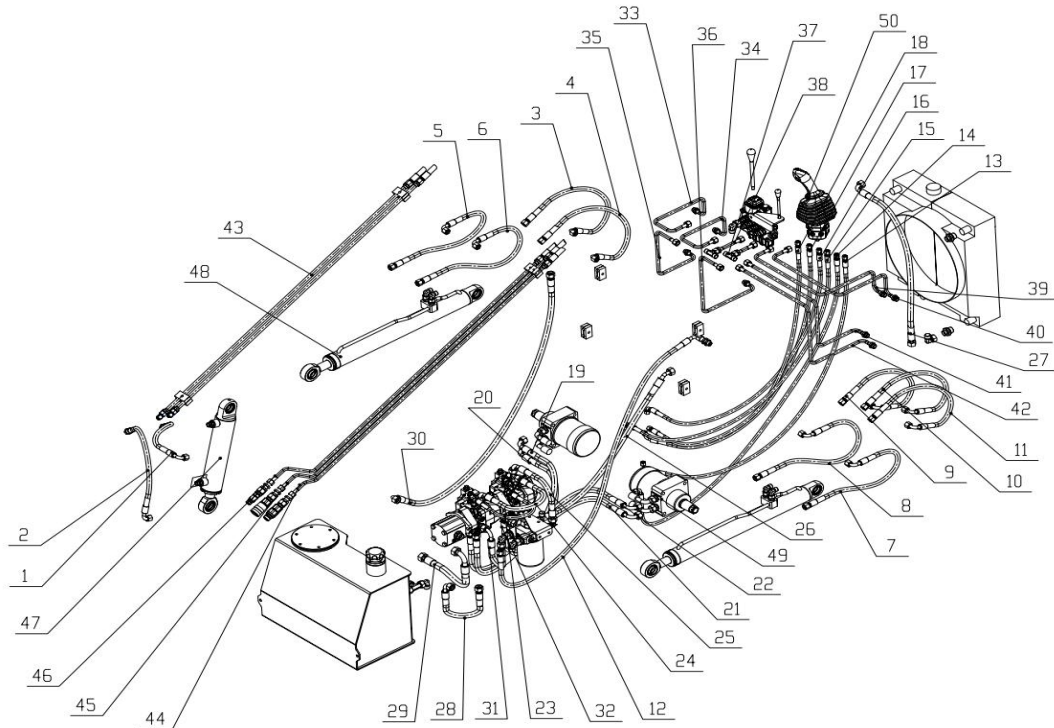

Parts list :

No	Part No	Description	Q'ty	Remark
1	680BF007-1	Hose assembly	1	2SN-DN10-M21513-06-18/M21593-06-18-480-SC
2	680BF007-2	Hose assembly	1	2SN-DN10-M21513-06-18/M21593-06-18-705-SC
3	680BF007-3	Hose assembly	2	2SN-DN10-M21513-06-18/M21593-06-18-700-SC
4	680BF007-4	Hose assembly	1	2SN-DN10-M21513-06-18/M21593-06-18-700-SC
5	680BF007-5	Hose assembly	1	2SN-DN10-M21513-06-18/M21593-06-18-850-SC
6	680BF007-6	Hose assembly	1	2SN-DN10-M21513-06-18/M21593-06-18-850-SC
7	680BF007-7	Hose assembly	1	2SN-DN10-M21513-06-18/M21593-06-18-850-SC
8	680BF007-8	Hose assembly	1	2SN-DN10-M21513-06-18/M21593-06-18-

				850-SC
9	680BF007-9	Hose assembly	1	2SN-DN10-M21513-06-18/M21593-06-18-700-SC
10	680BF007-10	Hose assembly	1	2SN-DN10-M21513-06-18/M21593-06-18-700-SC
11	680BF007-11	Hose assembly	1	1SN-DN10-M21513-06-18/M21593-06-18-700-SC
12	680BF007-12	Hose assembly	1	1SN-DN10-M21513-06-18/M21593-06-18-1920-SC
13	680BF007-13	Hose assembly	1	1SN-DN6-M21513-04-14/M21593-04-14-1760
14	680BF007-14	Hose assembly	1	1SN-DN6-M21513-04-14/M21593-04-14-1945
15	680BF007-15	Hose assembly	1	1SN-DN6-M21513-04-14/M21593-04-14-2100
16	680BF007-16	Hose assembly	1	1SN-DN6-M21513-04-14/M21593-04-14-2100
17	680BF007-17	Hose assembly	1	1SN-DN6-M21513-04-14/M21593-04-14-1765
18	680BF007-18	Hose assembly	1	1SN-DN6-M21513-04-14/M21593-04-14-1765
19	680BF007-19	Hose assembly	1	2SN-DN12-M21513-08-22/M21593-08-22 (H80)-515
20	680BF007-20	Hose assembly	1	2SN-DN12-M21513-08-22/M21593-08-22 (H80)-525
21	680BF007-21	Hose assembly	1	2SN-DN12-M21513-08-22/M21593-08-22-660
22	680BF007-22	Hose assembly	1	2SN-DN12-M21513-08-22/M21593-08-22-685
23	680BF007-23	Hose assembly	1	1SN-DN6-M21513-04-14/M21593-04-14-190
24	680BF007-24	Hose assembly	1	1SN-DN12-M21513-08-22/M21593-08-22-375
25	680BF007-25	Hose assembly	1	2SN-DN12-M21513-08-22/M21593-08-22-460
26	680BF007-26	Hose assembly	1	2SN-DN12-M21513-08-22/M21543-08-22-965
27	680BF007-27	Hose assembly	1	2SN-DN12-M21513-08-22/M21593-08-22-980
28	680BF007-28	Hose assembly	1	2SN-DN12-M21513-08-22/M21593-08-22-415

29	680BF007-29	Hose assembly	1	2SN-DN16-M21513-10-26/M21593-10-26-415
30	680BF007-30	Hose assembly	1	2SN-DN12-M21513-08-22/M21593-08-22-1700
31	680BF007-31	Hose assembly	1	1SN-DN12-M21513-08-22/M21593-08-22-420
32	680BF007-32	Hose assembly	1	1SN-DN12-M21513-08-22/M21593-08-22-420
33	680BF007-33	Rigid tube one	1	
34	680BF007-34	Tube two	1	
35	680BF007-35	Tube three	1	
36	680BF007-36	Tube four	1	
37	680BF007-37	Tube Five	1	
38	680BF007-38	Tube Six	1	
39	680BF007-39	Tube Seven	1	
40	680BF007-40	Tube Eight	1	
41	680BF007-41	Tube Nine	1	
42	680BF007-42	Tube ten	1	
43	680BF007-43	Tube Eleven	2	
44	680BF007-44	Tube Twelve	1	
45	680BF007-45	Tube XIII	1	
46	680BF007-46	Tube XIV	1	
47	680BF007-47	Dozer cylinders	1	
48	680BF007-48	Lift cylinders	2	
49	680BF007-49	Travel motor	2	MS375
50	680BF007-50	Controllers	1	

Battery assembly explosion diagram

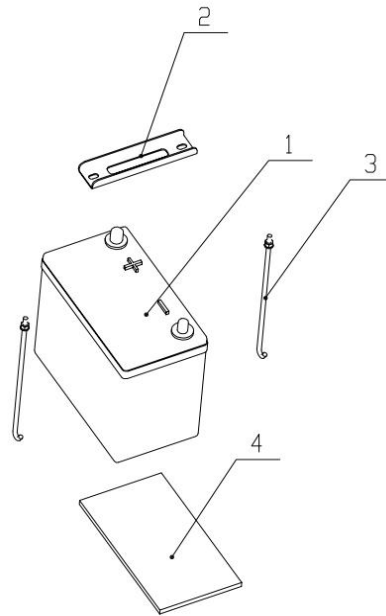

Parts list :

No	Part No	Description	Q'ty	Remark
1	680BF008-1	accumulator	1	45Ah
2	680BF008-2	Battery pressure plate	1	
3	680BF008-3	Battery hook	2	L=245
4	680BF008-4	Battery pads	1	

Explodiagram of operating panel assembly

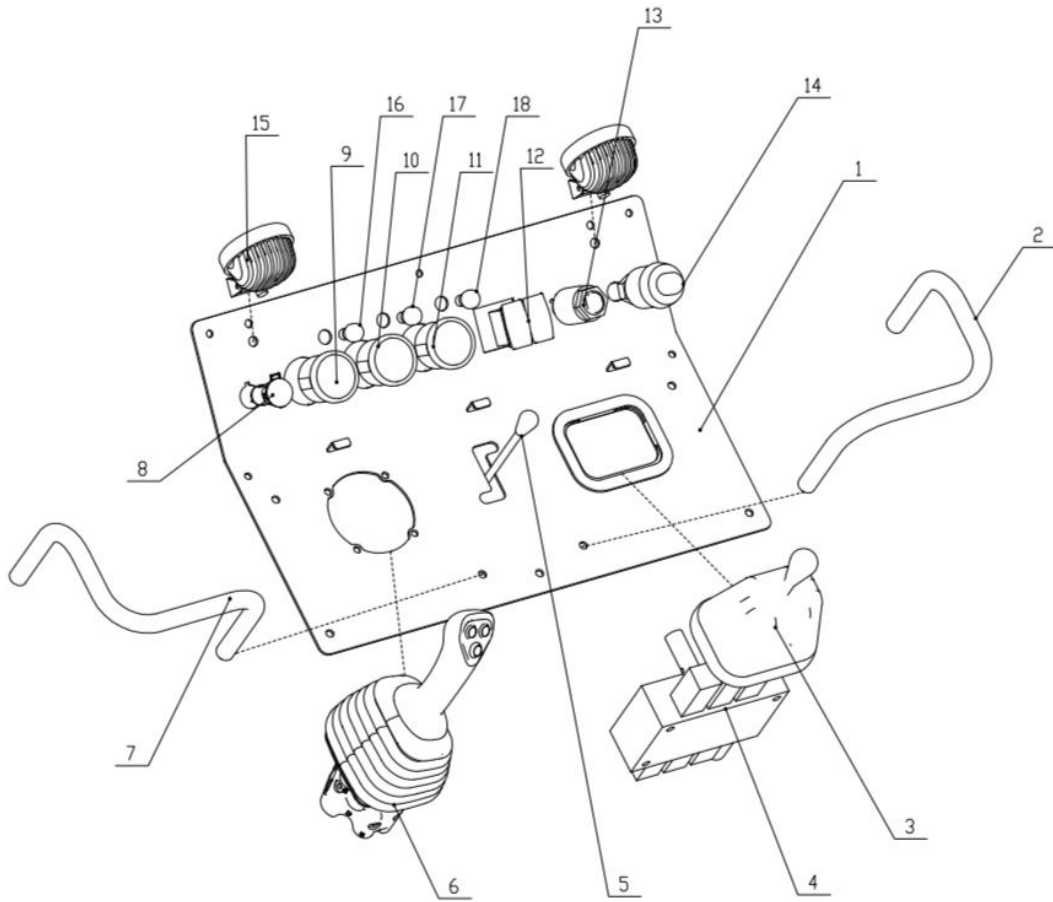

Parts list :

No	Part No	Description	Q'ty	Remark
1	680BF009-1	Operator panel assembly	1	
2	680BF009-2	Right armrest assembly	1	
3	680BF009-3	Dust bellows	1	
4	680BF009-4	Multiple coupling valves	1	
5	680BF009-5	Auxiliary tool control lever	1	
6	680BF009-6	Walk control handle	1	
7	680BF009-7	Left armrest assembly	1	
8	680BF009-8	Power hole	1	
9	680BF009-9	Fuel level gauge	1	12V,6A
10	680BF009-10	Water temperature indicator	1	
11	680BF009-11	Working chronograph	1	
12	680BF009-12	Work light switch	1	
13	680BF009-13	Start key	1	
14	680BF009-14	Control the throttle	1	

15	680BF009-15	Work lights	1	
16	680BF009-16	Oil pressure indicator light	1	
17	680BF009-17	Charging indicator light	1	
18	680BF009-18	Power LED	1	

QUESTION	REASON	ANSWER
The engine cannot start, the starter does not respond, and the instrument does not light up.	1.The battery is completely empty 2.cable link broken	1.Replace the battery or charge it 2.Check the disconnection and repair it
The engine cannot start. The starter can drive the engine to rotate.	1.The battery is low 2.Cables are loose 3.flooded cylinder	Recharge or replace battery Tighten cable glands Remove the spark plug. Start the machine with the key switch to remove excess fuel. Check the spark plug.
The engine can start but is difficult to start	1.Fuel level low 2.There is water in the fuel system 3.The fuel pipe is cracked 4.Fuel pump pressure is low 5.The engine oil model is wrong 6.Engine overheating	1.Add fuel to the appropriate location 2.Drain the water 3.Replace the fuel pipe 4.Replace and repair 5.Change the temperature and add appropriate type of engine oil. 6.Check the cooling system
The engine starts but runs erratically	1.Fuel system air intake 2.Engine speed regulator is loose 3.The fuel filter is clogged 4.The air filter is clogged	1.Replace the fuel line 2.Adjust the engine speed regulator 3.Replace filter element 4.Replace the air filter
Engine overheating	1.Cooling system blocked 2.Engine overload 3.The cooling system cover falls off 4.The fan belt is too loose	1.Clean and cool the tin tube 2.Adjust the engine speed to match the hydraulic system 3.Fasten the cover 4.Adjust the belt to the appropriate tension
The engine keeps emitting black smoke	1.The air filter is clogged 2.The amount of fuel injected by the fuel injection nozzle is too large.	1.Replace the air filter element 2.Replace the fuel injector
The engine emits white or blue smoke	1.Fuel quality is too poor 2.Too much oil is added	1.Replaced fuel 2.Add the appropriate position according to the engine oil dipstick
The whole machine has no action	1.Hydraulic pump damaged 2.The safety valve is damaged 3.The hydraulic oil model does not match the temperature. 4.The safety lock is not opened	1.Repair or replace 2.Replace the safety valve 3.Replace the appropriate hydraulic oil 4.Open the safety lock

<p>The whole machine moves slowly</p>	<ol style="list-style-type: none"> 1. Hydraulic oil level is too low 2. Hydraulic oil viscosity is too high 3. Control valve is damaged 4. cylinder internal leakage 5. The hydraulic pump is damaged" " 	<ol style="list-style-type: none"> 1. Add hydraulic oil to the appropriate oil level gauge 2. Heating the hydraulic oil while the engine is idling 3. Repair or replace 4. Inspect and repair 5. Repair or Replace"
<p>Unable to dig</p>	<ol style="list-style-type: none"> 1. Hydraulic oil level is too low 2. Hydraulic oil temperature is overheated 3. Hydraulic oil temperature is too low 4. The pressure safety valve is damaged 5. Hydraulic pump damaged 	<ol style="list-style-type: none"> 1. Add hydraulic oil to level 2. Check the cooling system 3. Machine idling to preheat hydraulic oil temperature 4. Replace the safety valve 5. Replace the hydraulic pump
<p>The machine shuts down when doing movements</p>	<ol style="list-style-type: none"> 1. Fuel oil line sucks air 2. Engine hydraulic pump power does not match 3. Hydraulic oil filter is clogged 	<ol style="list-style-type: none"> 1. Check the fuel line or replace it 2. Increase engine speed 3. Replace the hydraulic oil filter element
<p>Hydraulic oil temperature is too high</p>	<ol style="list-style-type: none"> 1. Hydraulic oil level is too low 2. Hydraulic filter element is clogged 3. The cooling system is blocked 	<ol style="list-style-type: none"> 1. Add hydraulic oil 2. Replace the hydraulic filter element 3. Clean the cooling system